

Study

Guide

Georgia End-Of-Course Tests

MATHEMATICS II:
GEOMETRY/ALGEBRA II/STATISTICS

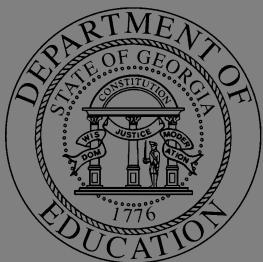

TABLE OF CONTENTS

INTRODUCTION	1
HOW TO USE THE STUDY GUIDE	2
OVERVIEW OF THE EOCT	4
Preparing FOR THE EOCT	5
Study Skills	5
Time Management	6
Organization.....	6
Active Participation	7
Test-taking Strategies.....	7
Suggested Strategies to Prepare for the EOCT	8
Suggested Strategies the Day before the EOCT	9
Suggested Strategies the Morning of the EOCT.....	9
Top 10 Suggested Strategies during the EOCT	10
TEST CONTENT	11
Studying the Content Standards and Topics	12
Unit 1: Quadratic Functions.....	13
Unit 2: Right Triangle Trigonometry.....	37
Unit 3: Circles and Spheres.....	43
Unit 4: Statistics: Data Analysis	66
Unit 5: Piecewise, Exponential, and Inverses.....	78
Unit 6: Statistics: Algebraic Models for Quantitative Data	105
APPENDICES	
APPENDIX A: EOCT Sample Overall Study Plan Sheet.....	120
APPENDIX B: Blank Overall Study Plan Sheet.....	121
APPENDIX C: EOCT Sample Daily Study Plan Sheet.....	122
APPENDIX D: Blank Daily Study Plan Sheet	123

**This Page Is Intentionally
Left Blank.**

INTRODUCTION

This study guide is designed to help students prepare to take the Georgia End-of-Course Test (EOCT) for *Mathematics II*. This study guide provides information about the EOCT, tips on how to prepare for it, and some suggested strategies students can use to perform their best.

What is the EOCT? The EOCT program was created to improve student achievement through effective instruction and assessment of the standards in the Georgia Performance Standards (GPS) specific to the eight EOCT core high school courses. The EOCT program also helps to ensure that all Georgia students have access to a rigorous curriculum that meets high performance standards. The purpose of the EOCT is to provide diagnostic data that can be used to enhance the effectiveness of schools' instructional programs.

The Georgia End-of-Course Testing program is a result of the A+ Educational Reform Act of 2000, O.C.G.A. §20-2-281. This act requires that the Georgia Department of Education create end-of-course assessments for students in grades 9 through 12 for the following core high school subjects:

Mathematics

- Mathematics I: Algebra/Geometry/Statistics
- Mathematics II: Geometry/Algebra II/Statistics

Social Studies

- United States History
- Economics/Business/Free Enterprise

Science

- Biology
- Physical Science

English Language Arts

- Ninth Grade Literature and Composition
- American Literature and Composition

Since the EOCT program is designed to measure a student's mastery of a specific curriculum, if the curriculum changes, so too must the test. This occurred in 2005, when the Georgia Department of Education modified and revised the state's Mathematics curriculum. This new curriculum was implemented in high school classrooms starting in 2007–2008. Due to this change, the *Mathematics II EOCT* was developed in order to reflect the updated standards, and this study guide has also been revised appropriately to cover the new set of standards.

HOW TO USE THE STUDY GUIDE

This study guide is designed to help you prepare to take the *Mathematics II EOCT*. It will give you valuable information about the EOCT, explain how to prepare to take the EOCT, and provide some opportunities to practice for the EOCT. The study guide is organized into three sections. Each section focuses on a different aspect of the EOCT.

The OVERVIEW OF THE EOCT section on page 4 gives information about the test: dates, time, question format, and number of questions that will be on the *Mathematics II EOCT*. This information can help you better understand the testing situation and what you will be asked to do.

The PREPARING FOR THE EOCT section that begins on page 5 provides helpful information on study skills and general test-taking skills and strategies. It explains how to prepare before taking the test and what to do during the test to ensure the best test-taking situation possible.

The TEST CONTENT section that begins on page 11 explains what the *Mathematics II EOCT* specifically measures. When you know the test content and how you will be asked to demonstrate your knowledge, it will help you be better prepared for the EOCT. This section also contains some sample EOCT test questions, helpful for gaining an understanding of how a standard may be tested.

With some time, determination, and guided preparation, you will be better prepared to take the *Mathematics II EOCT*.



GET IT TOGETHER

In order to make the most of this study guide, you should have the following:

Materials:

- * This study guide
- * Pen or pencil
- * Highlighter
- * Paper

Resources:

- * Classroom notes
- * Mathematics textbook
- * A teacher or other adult

Study Space:

- * Comfortable (but not too comfortable)
- * Good lighting
- * Minimal distractions
- * Enough work space

Time Commitment:

- * When are you going to study?
- * How long are you going to study?

Determination:

- * Willingness to improve
- * Plan for meeting goals



SUGGESTED STEPS FOR USING THIS STUDY GUIDE

- 1** Familiarize yourself with the structure and purpose of the study guide. (You should have already read the INTRODUCTION and HOW TO USE THE STUDY GUIDE. Take a few minutes to look through the rest of the study guide to become familiar with how it is arranged.)
- 2** Learn about the test and expectations of performance. (Read OVERVIEW OF THE EOCT.)
- 3** Improve your study skills and test-taking strategies. (Read PREPARING FOR THE EOCT.)
- 4** Learn what the test will assess by studying each unit and the strategies for answering questions that assess the standards in the unit. (Read TEST CONTENT.)
- 5** Answer the sample test question at the end of each lesson. Check your answer against the answer given to see how well you did. (See TEST CONTENT.)

OVERVIEW OF THE EOCT

Good test takers understand the importance of knowing as much about a test as possible. This information can help you determine how to study and prepare for the EOCT and how to pace yourself during the test. The box below gives you a snapshot of the *Mathematics II EOCT* and other important information.



THE EOCT AT A GLANCE

Administration Dates:

The EOCT has three primary annual testing dates: once in the spring, once in the summer, and once in the winter. There are also mid-month, online tests given in August, September, October, November, February, and March.

Administration Time:

Each EOCT is composed of two sections, and students are given 60 minutes to complete each section. There is also a short stretch break between the two sections of the test.

Question Format:

All the questions on the EOCT are multiple-choice.

Number of Questions:

Each section of the *Mathematics II EOCT* contains 31 questions; there are a total of 62 questions on the *Mathematics II EOCT*.

Impact on Course Grade:

A student's EOCT score is averaged in as 15% of his/her final course grade.

If you have additional administrative questions regarding the EOCT, please visit the Georgia Department of Education Web site at www.doe.k12.ga.us, see your teacher, or see your school test coordinator.

PREPARING FOR THE EOCT



WARNING!

You cannot prepare for this kind of test in one night. Questions will ask you to apply your knowledge, not list specific facts. Preparing for the EOCT will take time, effort, and practice.



To do your best on the *Mathematics II EOCT*, it is important that you take the time necessary to prepare for this test and develop those skills that will help you take the EOCT.

First, you need to make the most of your classroom experiences and test preparation time by using good **study skills**. Second, it is helpful to know general **test-taking strategies** to ensure that you will achieve your best score.

Study Skills



A LOOK AT YOUR STUDY SKILLS

Before you begin preparing for this test, you might want to consider your answers to the following questions. You may write your answers here or on a separate piece of paper.

1. How would you describe yourself as a student?
Response: _____
2. What are your study skills strengths and/or weaknesses as a student?
Response: _____
3. How do you typically prepare for a mathematics test?
Response: _____
4. Are there study methods you find particularly helpful? If so, what are they?
Response: _____
5. Describe an ideal study situation (environment).
Response: _____
6. Describe your actual study environment.
Response: _____
7. What can you change about the way you study to make your study time more productive?
Response: _____

Effective study skills for preparing for the EOCT can be divided into three categories:

- ◆ **Time Management**
- ◆ **Organization**
- ◆ **Active Participation**



Time Management

Do you have a plan for preparing for the EOCT? Often students have good intentions for studying and preparing for a test, but without a plan, many students fall short of their goals. Here are some strategies to consider when developing your study plan:

- ◆ Set realistic goals for what you want to accomplish during each study session and chart your progress.
- ◆ Study during your most productive time of the day.
- ◆ Study for reasonable amounts of time. Marathon studying is not productive.
- ◆ Take frequent breaks. Breaks can help you stay focused. Doing some quick exercises (e.g., sit-ups or jumping jacks) can help you stay alert.
- ◆ Be consistent. Establish your routine and stick to it.
- ◆ Study the most challenging test content first.
- ◆ For each study session, build in time to review what you learned in your last study session.
- ◆ Evaluate your accomplishments at the end of each study session.
- ◆ Reward yourself for a job well done.

Organization

You don't want to waste your study time. Searching for materials, trying to find a place to study, and debating what and how to study can all keep you from having a productive study session. Get organized and be prepared. Here are a few organizational strategies to consider:



- ◆ Establish a study area that has minimal distractions.
- ◆ Gather your materials in advance.
- ◆ Develop and implement your study plan (see Appendices A–D for sample study plan sheets).

Active Participation



Students who actively study will learn and retain information longer. Active studying also helps you stay more alert and be more productive while learning new information. What is active studying? It can be anything that gets you to interact with the material you are studying. Here are a few suggestions:

- ◆ Carefully read the information and then **DO** something with it. Mark the important points with a highlighter, circle it with a pen, write notes on it, or summarize the information in your own words.
- ◆ Ask questions. As you study, questions often come into your mind. Write them down and actively seek the answers.
- ◆ Create sample test questions and answer them.
- ◆ Find a friend who is also planning to take the test and quiz each other.

Test-taking Strategies

There are many test-taking strategies that you can use before and during a test to help you have the most successful testing situation possible. Below are a few questions to help you take a look at your test-taking skills.



A LOOK AT YOUR TEST-TAKING SKILLS

As you prepare to take the EOCT, you might want to consider your answers to the following questions. You may write your answers here or on your own paper.

1. How would you describe your test-taking skills?
Response: _____
2. How do you feel when you are taking a test?
Response: _____
3. List the strategies that you already know and use when you are taking a test.
Response: _____
4. List test-taking behaviors you use that contribute to your success when preparing for and taking a test.
Response: _____
5. What would you like to learn about taking tests?
Response: _____

Suggested Strategies to Prepare for the EOCT

 **Learn from the past.** Think about your daily/weekly grades in your mathematics classes (past and present) to answer the following questions:

- In which specific areas of mathematics were you or are you successful?

Response: _____

- Is there anything that has kept you from achieving higher scores?

Response: _____

- What changes should you implement to achieve higher scores?

Response: _____

Before taking the EOCT, work toward removing or minimizing any obstacles that might stand in the way of performing your best. The test preparation ideas and test-taking strategies in this section are designed to help guide you to accomplish this.

 **Be prepared.** The best way to perform well on the EOCT is to be prepared. In order to do this, it is important that you know what standards/skills will be measured on the **Mathematics II EOCT** and then practice understanding and using those standards/skills. The TEST CONTENT section of this study guide is designed to help you understand the specific standards that are on the **Mathematics II EOCT** and give you suggestions for how to study the standards that will be assessed. Take the time to read through this material and follow the study suggestions. You can also ask your math teacher for any suggestions he or she might offer on preparing for the EOCT.

 **Start now.** Don't wait until the last minute to start preparing. Begin early and pace yourself. By preparing a little bit each day, you will retain the information longer and increase your confidence level. Find out when the EOCT will be administered, so you can allocate your time appropriately.

Suggested Strategies the Day before the EOCT

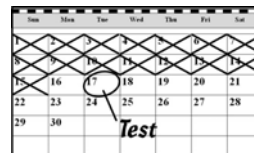

- ✓ **Review what you learned from this study guide.**
 1. Review the general test-taking strategies discussed in the TOP 10 SUGGESTED STRATEGIES DURING THE EOCT on page 10.
 2. Review the content information discussed in the TEST CONTENT section beginning on page 11.
 3. Focus your attention on the main topic, or topics, that you are most in need of improving.

- ✓ **Take care of yourself.**
 1. Try to get a good night's sleep. Most people need an average of eight hours, but everyone's sleep needs are different.
 2. Don't drastically alter your routine. If you go to bed too early, you might lie in bed thinking about the test. You want to get enough sleep so you can do your best.

Suggested Strategies the Morning of the EOCT



Eat a good breakfast. Choose foods high in protein for breakfast (and for lunch if the test is given in the afternoon). Some examples of foods high in protein are peanut butter, meat, and eggs. Protein gives you long-lasting, consistent energy that will stay with you through the test to help you concentrate better. Avoid foods high in sugar content. It is a misconception that sugar sustains energy—after an initial boost, sugar will quickly make you more tired and drained. Also, don't eat too much. A heavy meal can make you feel tired. So think about what you eat before the test.



Dress appropriately. If you are too hot or too cold during the test, it can affect your performance. It is a good idea to dress in layers, so you can stay comfortable, regardless of the room temperature, and keep your mind on the EOCT.







Arrive for the test on time. Racing late into the testing room can cause you to start the test feeling anxious. You want to be on time and prepared.

TOP 10

Suggested Strategies during the EOCT

These general test-taking strategies can help you do your best during the EOCT.

- 1 Focus on the test.**  Try to block out whatever is going on around you. Take your time and think about what you are asked to do. Listen carefully to all the directions.
- 2 Budget your time.**  Be sure that you allocate an appropriate amount of time to work on each question on the test.
- 3 Take a quick break if you begin to feel tired.** To do this, put your pencil down, relax in your chair, and take a few deep breaths. Then, sit up straight, pick up your pencil, and begin to concentrate on the test again. Remember that each test section is only 60 minutes.
- 4 Use positive self-talk.** If you find yourself saying negative things to yourself such as “I can’t pass this test,” it is important to recognize that you are doing this. Stop and think positive thoughts such as “I prepared for this test, and I am going to do my best.” Letting the negative thoughts take over can affect how you take the test and your test score.
- 5 Mark in your test booklet.**  Mark key ideas or things you want to come back to in your test booklet. Remember that only the answers marked on your answer sheet will be scored.
- 6 Read the entire question and the possible answer choices.** It is important to read the entire question so you know what it is asking. Read each possible answer choice. Do not mark the first one that “looks good.”
- 7 Use what you know.**  Draw on what you have learned in class, from this study guide, and during your study sessions to help you answer the questions.
- 8 Use content domain-specific strategies to answer the questions.** In the TEST CONTENT section, there are a number of specific strategies that you can use to help improve your test performance. Spend time learning these helpful strategies, so you can use them while taking the test.
- 9 Think logically.** If you have tried your best to answer a question but you just aren’t sure, use the process of elimination. Look at each possible answer choice. If it doesn’t seem like a logical response, eliminate it. Do this until you’ve narrowed down your choices. If this doesn’t work, take your best educated guess. It is better to mark something down than to leave it blank.
- 10 Check your answers.** When you have finished the test, go back and check your work.

A WORD ON TEST ANXIETY

It is normal to have some stress when preparing for and taking a test. It is what helps motivate us to study and try our best. Some students, however, experience anxiety that goes beyond normal test “jitters.” If you feel you are suffering from test anxiety that is keeping you from performing at your best, please speak to your school counselor, who can direct you to resources to help you address this problem.

TEST CONTENT

Up to this point in this study guide, you have been learning various strategies on how to prepare for and take the EOCT. This section focuses on what will be tested. It also includes sample questions that will let you apply what you have learned in your classes and from this study guide.

This section of the study guide will help you learn and review the various mathematical concepts that will appear on the *Mathematics II EOCT*. Since *mathematics* is a broad term that covers many different topics, the state of Georgia has divided it into three major areas of knowledge called **content strands**. The content strands are broad categories. Each of the content strands is broken down into big ideas. These big ideas are called **content standards** or just standards. Each content strand contains standards that cover different ideas related to the content strand. Each question on the EOCT measures an individual standard within a content strand.

The three content strands for the *Mathematics II EOCT* are Algebra, Geometry, and Data Analysis and Probability. They are important for several reasons. Together, they cover the major skills and concepts needed to understand and solve mathematical problems. These skills have many practical applications in the real world. Another more immediate reason that the content strands are important has to do with test preparation. The best way to prepare for any test is to study and know the material measured on the test.

This study guide is organized in six **units** that review the material covered within the six units of the Mathematics II GPS Frameworks. It is presented by topic rather than by strand or standard (although those are listed at the beginning of each unit and are integral to each topic). The more you understand about the topics in each unit, the greater your chances of getting a good score on the EOCT.

Studying the Content Standards and Topics (Unit 1—Unit 6)

You should be familiar with many of the content standards and topics that follow. It makes sense to spend more time studying the content standards and topics that you think may cause you problems. Even so, do not skip over any of them. The TEST CONTENT section has been organized into six units. Each unit is organized by the following features:

- **Introduction:** an overview of what will be discussed in the unit
- **Key Standards:** information about the specific standards that will be addressed
(NOTE: The names of the standards may not be the exact names used by the Georgia Department of Education.)

- **Main Topics:** the broad subjects covered in the unit

Each Main Topic includes:

- **Key Ideas:** definitions of important words and ideas as well as descriptions, examples, and steps for solving problems.
- **Review Examples:** problems with solutions showing possible ways to answer given questions
- **EOCT Practice Items:** sample multiple-choice questions similar to test items on the *Mathematics II EOCT* with answer keys provided

With some time, determination, and guided preparation, you will be better prepared to take the *Mathematics II EOCT*.

Unit 1 Quadratic Functions

This unit extends the study of quadratic functions to include in-depth analysis of general quadratic functions in both the standard form $f(x) = ax^2 + bx + c$ and in the vertex form $f(x) = a(x - h)^2 + k$, which is introduced in this unit. Strategies for finding solutions to quadratic equations are extended to include solving them through factoring and using the quadratic formula, which can be used to solve any quadratic equation. Study of the quadratic formula introduces complex numbers; the arithmetic of complex numbers also is introduced and explored. Connections are made between algebraic results and characteristics of the graphics of quadratic functions. These connections are used to solve quadratic equations and inequalities. In addition, sums of terms of finite arithmetic sequences are explored as examples of a quadratic function. Interval notation is commonly used for representing an interval (such as a domain, range, or solution set) as a pair of numbers. This work provides a foundation for modeling data with quadratic functions, a topic that will be explored later in Mathematics II.

KEY STANDARDS

MM2N1. Students will represent and operate with complex numbers.

- a. Write square roots of negative numbers in imaginary form.
- b. Write complex numbers in the form $a + bi$.
- c. Add, subtract, multiply, and divide complex numbers.
- d. Simplify expressions involving complex numbers.

MM2A3. Students will analyze quadratic functions in the forms $f(x) = ax^2 + bx + c$ and $f(x) = a(x - h)^2 + k$.

- a. Convert between standard and vertex form.
- b. Graph quadratic functions as transformations of the function $f(x) = x^2$.
- c. Investigate and explain characteristics of quadratic functions, including domain, range, vertex, axis of symmetry, zeros, intercepts, extrema, intervals of increase and decrease, and rates of change.
- d. Explore arithmetic series and various ways of computing their sums.
- e. Explore sequences of partial sums of arithmetic series as examples of quadratic functions.

MM2A4. Students will solve quadratic equations and inequalities in one variable.

- a. Solve equations graphically using appropriate technology.
- b. Find real and complex solutions of equations by factoring, taking square roots, and applying the quadratic formula.
- c. Analyze the nature of roots using technology and using the discriminant.
- d. Solve quadratic inequalities both graphically and algebraically, and describe the solutions using linear inequalities.

QUADRATIC FUNCTIONS



KEY IDEAS

1. Quadratic functions can be located on a coordinate plane by horizontal and vertical shifts of the graph of the function $f(x) = x^2$.

A **horizontal shift** of h units is represented by the function $f(x) = (x - h)^2$. Note that if h is positive, i.e., the graph is shifted to the right, h is subtracted from x . If h is negative, i.e., the graph is shifted to the left, h is added to x .

A **vertical shift** of k units is represented by the function $f(x) = x^2 + k$. In this case, the direction of the shift agrees with the operation in the function.

Horizontal and vertical shifts can be combined. If the graph of $f(x) = x^2$ is translated so its vertex is at the point (h, k) , it is represented by the function $f(x) = (x - h)^2 + k$.

2. The factor of x^2 represents the amount of **vertical stretch** or **shrink** applied to the graph of $f(x) = x^2$. This factor also determines whether the graph opens up, i.e., has a vertex with a y -coordinate that represents a **minimum** value of $f(x)$, or opens down, i.e., has a vertex with a y -coordinate that represents a **maximum** value of $f(x)$.

The general equation for a function with a vertex at the point (h, k) and a vertical stretch factor of a is represented by the function $f(x) = a(x - h)^2 + k$.

Example:

- a. Graph $y = x^2$ and $y = (x - 3)^2$.
- b. Make a table to show the values of x and y for both equations for $x = -2, -1, 0, 1, 2, 3, 4,$ and 5 .
- c. Describe how subtracting 3 from the value of x in the parent function $y = x^2$ affects the graph of $y = (x - 3)^2$.

Solution:

a.

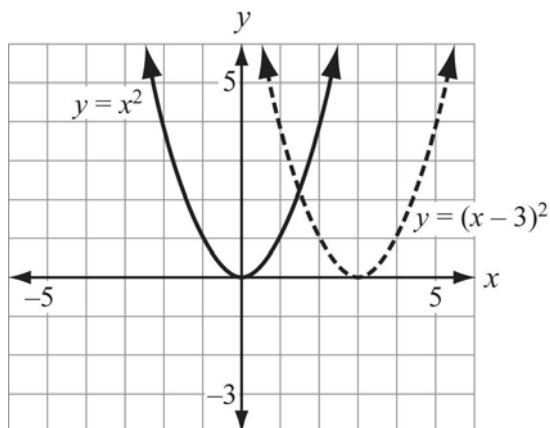

b.

x	x^2	$(x-3)^2$
-2	4	25
-1	1	16
0	0	9
1	1	4
2	4	1
3	9	0
4	16	1
5	25	4

c. When 3 is subtracted from the value of x , the values of $(x-3)^2$ are displaced by 3 units from the values of x^2 . Therefore, the graph is shifted 3 units to the right.

Example:

- Graph $y = x^2$ and $y = (x+2)^2$.
- Make a table to show the values of x and y for both equations for $x = -4, -3, -2, -1, 0, 1, 2,$ and 3 .
- Describe how adding 2 to the value of x in the parent function $y = x^2$ affects the graph of $y = (x+2)^2$.

Solution:

a.

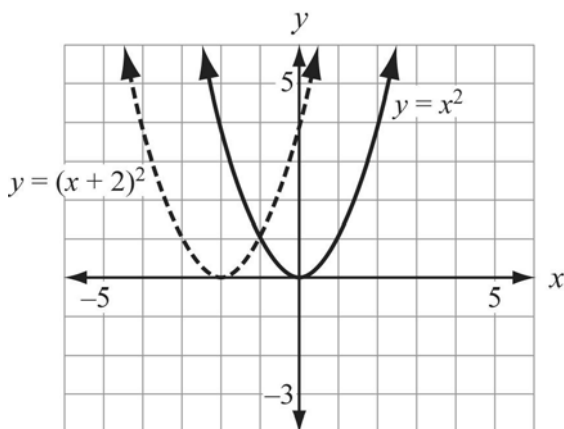

b.

x	x^2	$(x+2)^2$
-4	16	4
-3	9	1
-2	4	0
-1	1	1
0	0	4
1	1	9
2	4	16
3	9	25

c. When 2 is added to the value of x , the values of $(x+2)^2$ are displaced by 2 units from the values of x^2 . Therefore, the graph is shifted 2 units to the left.

Example:

- Graph $y = x^2$ and $y = (x - 4)^2 + 3$.
- Describe how the graph of $y = x^2$ is translated to get the graph of $y = (x - 4)^2 + 3$.

Solution:

a.

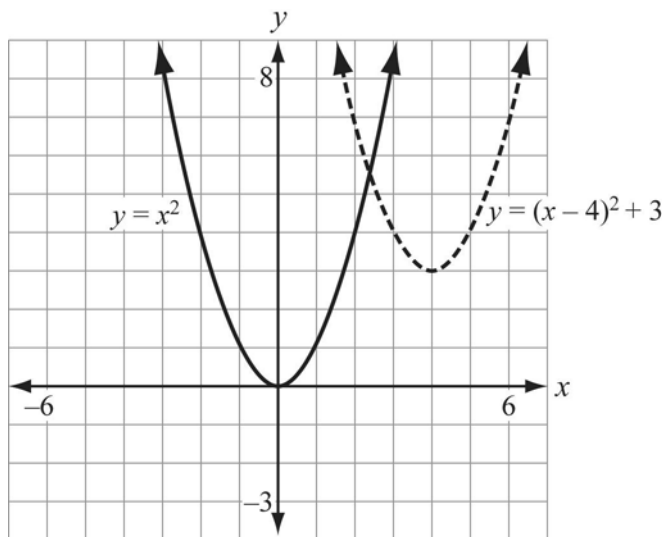

- The graph of $y = x^2$ is translated by 4 units to the right and 3 units up.
- The **vertex** and **axis of symmetry** of a quadratic function can be determined directly from the representation of the function in the form $f(x) = a(x - h)^2 + k$. The vertex is located at the point (h, k) and the axis of symmetry is the line $x = h$.
 - For a function represented in standard form as $f(x) = ax^2 + bx + c$, the vertex is located at the point $\left(\frac{-b}{2a}, f\left(\frac{-b}{2a}\right)\right)$ and the axis of symmetry is the line $x = \frac{-b}{2a}$.

Example:

Sketch the graph of the function $y = x^2 - 8x + 19$ on the coordinate plane. Identify the vertex and the axis of symmetry of the function. Write the same function in the form $y = (x - h)^2 + k$.

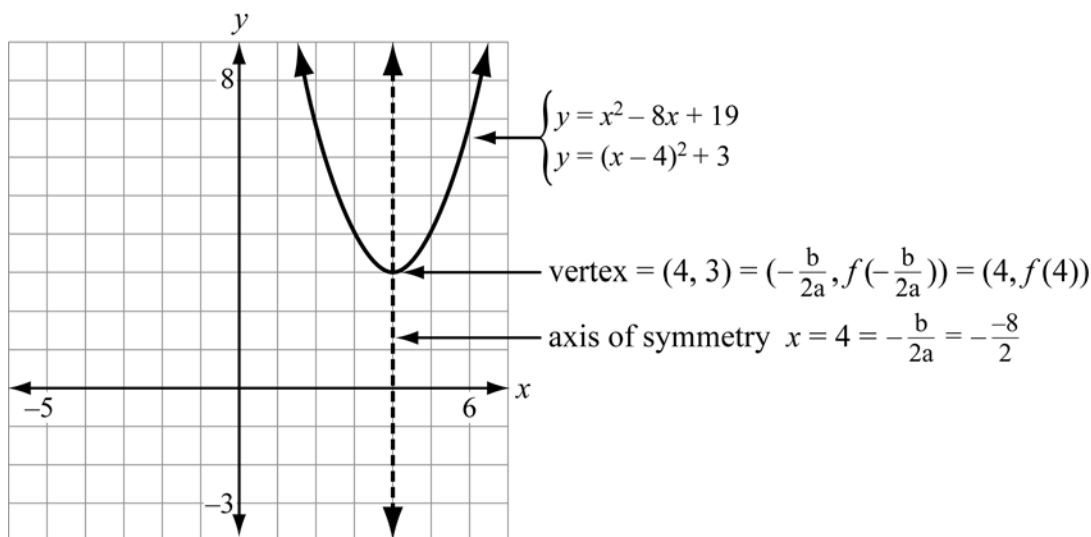
Solution:

5. Every quadratic function has either a **maximum** or a **minimum value** at the vertex. For a quadratic function where a is positive, the value of $f(x)$ at the vertex represents the minimum value of the function. From the left of the vertex to the vertex, the function *decreases at a decreasing rate*. From the right of the vertex to the vertex, the function *increases at an increasing rate*. The rate of increase or decrease is determined by the absolute value of a . For a quadratic function where a is negative, the value of $f(x)$ at the vertex represents the maximum value of the function. To the left of the vertex, the function *increases at a decreasing rate*. To the right of the vertex, the function *decreases at an increasing rate*. The rate of increase or decrease is determined by the absolute value of a .
6. The x -intercept or intercepts of a quadratic function are also called the **zeros** of the function. This is because the value of $f(x)$ is 0 at those points. A quadratic equation may have 0, 1, or 2 real zeros. The zeros on the graph correspond to the **real solutions** of the quadratic equation when it is set equal to 0.

Example:

2 Real Solutions

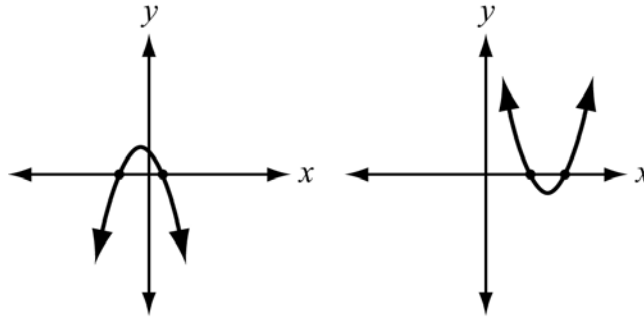

Exactly 1 Real Solution

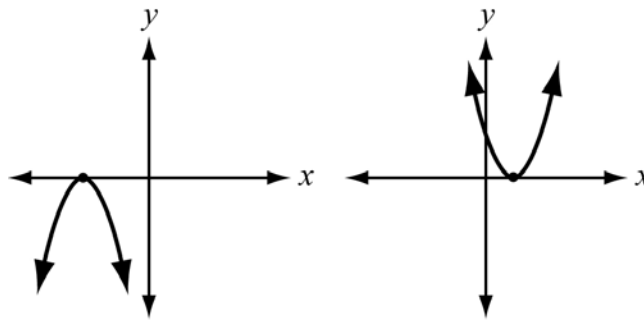

No Real Solutions

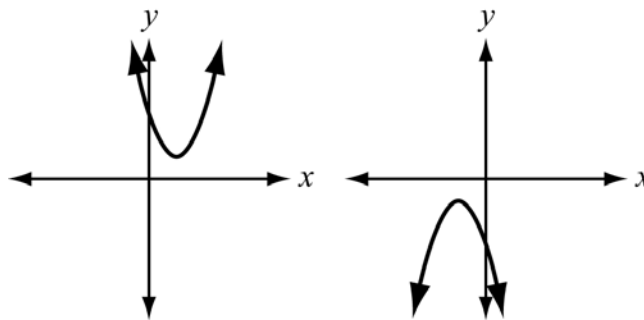

Example:

Sketch the graph of $f(x) = -\frac{1}{2}(x-2)^2 + 2$ on the coordinate plane. Identify the vertex, the maximum or minimum value, the increasing and decreasing behavior, and the zeros of $f(x)$.

Solution:

We know from the function that the graph has a vertex at $(2, 2)$, it opens down, and has a width that is twice the width of $f(x) = x^2$. The sketch of the graph is shown below.

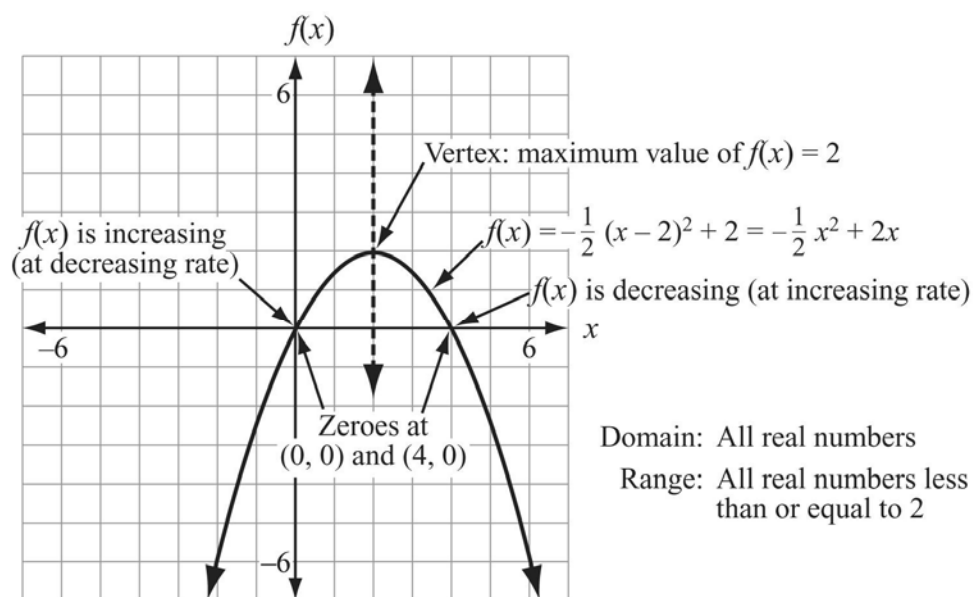

Example:

This graph shows a quadratic function. Identify the minimum value of the function, and show that the function is increasing at an increasing rate for $x > 4$. What is the value of a for this function?

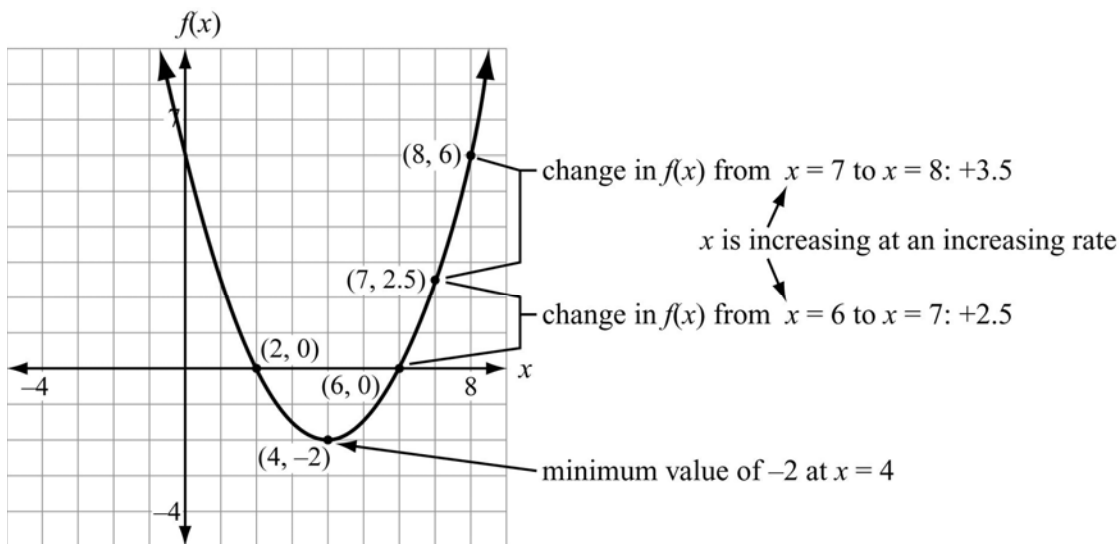

Solution:

Minimum value of $f(x)$	Occurs at low point of graph. At that point, the value of x is 4 and the value of $f(x)$ is -2 .
Behavior for $x > 4$	At $x = 4$, the value of $f(x)$ is -2 . At $x = 5$, the value of $f(x)$ is -1.5 . At $x = 6$, the value of $f(x)$ is 0 . At $x = 7$, the value of $f(x)$ is 2.5 . At $x = 8$, the value of $f(x)$ is 6 . As x increases, the value of $f(x)$ increases as well. The amount of increase is greater each time x increases by 1, so $f(x)$ is increasing at an increasing rate for $x > 4$.
Value of a	The step-by-step increase in the value of $f(x)$ for each of the steps listed above is 0.5 , 1.5 , 2.5 , and 3.5 . Each of these steps is half of the corresponding step for the function $f(x) = x^2$ when starting from the vertex of the function. Since $f(x)$ has a minimum, a is positive. Therefore, $a = \frac{1}{2}$.



Important Tip

You can make a table of values to help determine the value of a if the graph is difficult to read precisely at the points that are 1 unit (in terms of x -value) from the vertex. For $a = 1$, the absolute value of the change in $f(x)$ for each 1-unit change in x is the set of odd numbers: 1, 3,

5, 7, ... For $a = \frac{1}{2}$, the corresponding values are $\frac{1}{2} \cdot 1 = \frac{1}{2}$, $\frac{1}{2} \cdot 3 = 1\frac{1}{2}$, $\frac{1}{2} \cdot 5 = 2\frac{1}{2}$,

$\frac{1}{2} \cdot 7 = 3\frac{1}{2}$, ...

REVIEW EXAMPLES

- 1) This graph represents a quadratic function.

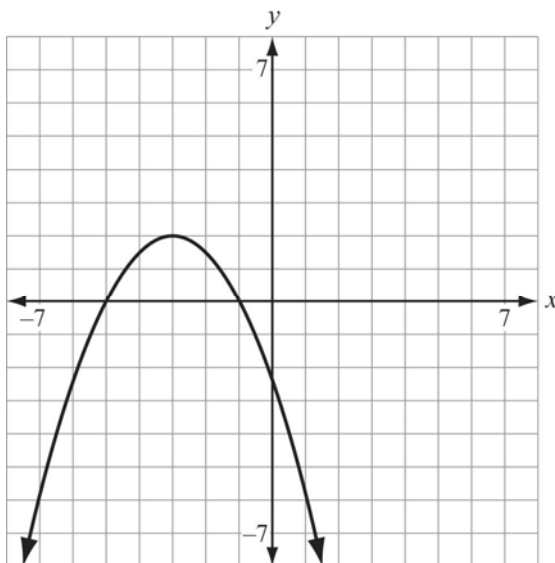

- Identify the location of the vertex.
- Write an equation to represent the axis of symmetry.
- Describe the horizontal and vertical shifts and the vertical stretch or shrink that could be applied to the graph of $y = x^2$ to get this graph.
- Write an equation in the form $y = a(x - h)^2 + k$ to represent this function.
- What are the zeros and the y -intercept of the function?
- What are the domain and range of the function?
- On what interval or intervals is the function increasing? On what interval or intervals is the function decreasing? For each interval, state whether the rate of increase or decrease is increasing or decreasing.

Solution:

- a. $(-3, 2)$
- b. $x = -3$
- c. Horizontal shift: 3 units left
Vertical shift: 2 units up
Stretch factor: $-\frac{1}{2}$
- d. $y = -\frac{1}{2}(x + 3)^2 + 2$
- e. Zeros: -5 and -1 ; y -intercept: -2.5 (or $-\frac{5}{2}$)
- f. Domain: $\{-\infty < x < \infty\}$, or $(-\infty, \infty)$ Range: $\{-\infty < y \leq 2\}$, or $(-\infty, 2]$
- g. The function is increasing on the interval $\{-\infty < x < -3\}$, or $(-\infty, -3)$; the rate of increase is decreasing for the whole interval. The function is decreasing on the interval $\{-3 < x < \infty\}$, or $(-3, \infty)$; the rate of decrease is increasing for the whole interval.

- 2) Philip is standing on a rock ledge that juts out over a lake. He tosses a rock straight up with a velocity of 48 feet per second. The rock leaves his hand at a point 64 feet above the surface of the lake. The rock travels upward and then falls into the lake.

This graph and table represent the height above the water, $h(t)$, as a function of the time, t , in seconds after Philip releases the rock.

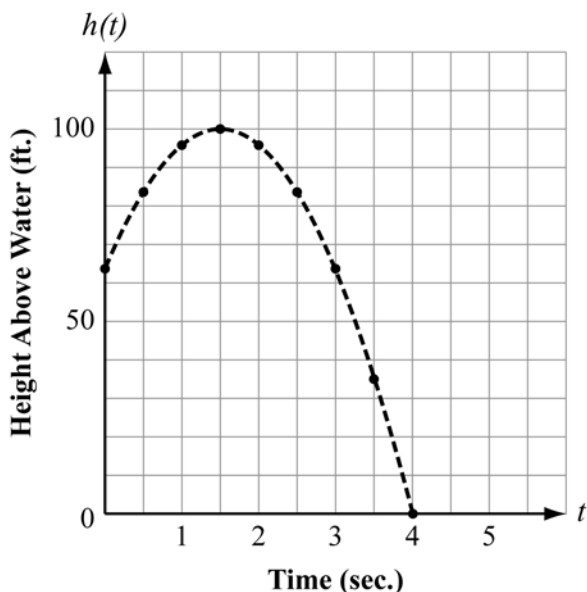

Time (t)	Height ($h(t)$)
0	64
1	96
2	96
3	64
4	0

- What is the maximum height the rock reaches above the surface of the lake?
- After how many seconds does the rock hit the surface of the lake?
- Identify the vertex and the axis of symmetry of the graph.
- What does the y -intercept of the graph represent in this context? What does the x -intercept represent?
- For approximately how many seconds is the rock at least 80 feet above the surface of the lake?
- Write a function in the form $h(t) = a(t - h)^2 + k$ that is represented by the graph.
- In this problem, what are the domain and range of $h(t)$?
- Write the function from part f in standard form $[h(t) = at^2 + bt + c]$.
- Explain how the values of a , b , and c in the function you wrote in part h relate to the problem situation.

Solution:

- 100 feet
- 4 seconds
- Vertex: $(1.5, 100)$; Axis of symmetry: $t = 1.5$ seconds
- The y -intercept represents the height from which Philip released the rock. The x -intercept represents the time, t , at which the rock hit the surface of the lake.
- About 2.2 seconds

f. $h(t) = -16(t - 1.5)^2 + 100$

g. Domain: $0 \leq t \leq 4$, or $[0, 4]$ Range: $0 \leq h(t) \leq 100$, or $[0, 100]$

h. $h(t) = -16t^2 + 48t + 64$

i. $-16 \left(\frac{\text{ft.}}{\text{sec}^2} \right)$ is the force of gravity (negative means it's in the downward direction)

$48 \left(\frac{\text{ft.}}{\text{sec}} \right)$ is the initial velocity of the rock (positive means it's in the upward direction)

64 (ft.) is the initial height of the rock when it was released

EOCT Practice Items

1) The quadratic function $f(x)$ has these characteristics:

- The vertex is located at $(8, -2)$.
- The range is $-2 \leq f(x) < \infty$.

Which function could be $f(x)$?

- A. $f(x) = \frac{1}{2}x^2 - 8x + 30$
- B. $f(x) = \frac{1}{2}x^2 - 8x + 31$
- C. $f(x) = -\frac{1}{2}x^2 + 8x - 34$
- D. $f(x) = -\frac{1}{2}x^2 - 2x + 6$

[Key: A]

2) The vertex of the quadratic function $g(x)$ is located at $(4, 2)$. An x -intercept of $g(x)$ is located at $(5, 0)$. What is the y -intercept of $g(x)$?

- A. $(0, -30)$
- B. $(0, -14)$
- C. $(0, -4)$
- D. $(0, 3)$

[Key: A]

SOLUTIONS OF QUADRATIC FUNCTIONS



KEY IDEAS

1. Factorable quadratic equations can be solved using this property of multiplication:

$$\text{if } ab = 0, \text{ then either } a = 0 \text{ or } b = 0$$

Thus, if $(x-p)(x-q) = 0$, then $(x-p) = 0$ or $(x-q) = 0$; i.e., $x = p$ or $x = q$.

2. Quadratic equations in the vertex form $[0 = a(t-h)^2 - k]$ can be solved by adding k to each side and dividing by a to get $\frac{k}{a} = (t-h)^2$; this means $(t-h) = \pm\sqrt{\frac{k}{a}}$ and, therefore,
- $$t = h \pm \sqrt{\frac{k}{a}}.$$

3. The **quadratic formula** gives a general solution to **any** quadratic equation of the form $0 = ax^2 + bx + c$. The formula expresses the values of x that are solutions as follows:

$$x = \frac{-b \pm \sqrt{b^2 - 4ac}}{2a}$$

The value of the **discriminant**, $b^2 - 4ac$, determines the number and character of the solutions to a quadratic equation.

- If $b^2 - 4ac > 0$, the equation has **two** real solutions.
- If $b^2 - 4ac = 0$, the equation has **exactly one** real solution.
- If $b^2 - 4ac < 0$, the equation has **no** real solutions; there are two **complex** solutions.

Note that the number and character of the solutions to a quadratic equation correspond to the number of zeros of the graph of the quadratic function, as illustrated in Key Idea #6 on pages 17–18.

REVIEW EXAMPLES

- 1) Consider the function $f(x) = -\frac{1}{2}(x+3)^2 + 2$ from the previous set of review examples.
- Solve the equation $f(x) = 0$.
 - Write the function in standard form and use the quadratic formula to verify the solutions you found in part a.

Solution:

$$\text{a. } 0 = -\frac{1}{2}(x+3)^2 + 2$$

$$-2 = -\frac{1}{2}(x+3)^2$$

$$4 = (x+3)^2$$

$$(x+3) = 2 \text{ or } (x+3) = -2$$

$$x = -1 \text{ or } x = -5$$

$$\text{b. } 0 = -\frac{1}{2}x^2 - 3x - \frac{5}{2}$$

$$x = \frac{-(-3) \pm \sqrt{(-3)^2 - 4\left(-\frac{1}{2}\right)\left(-\frac{5}{2}\right)}}{2\left(-\frac{1}{2}\right)}$$

$$x = \frac{3 \pm \sqrt{9 - 4\left(\frac{5}{4}\right)}}{-1}$$

$$x = \frac{3 \pm \sqrt{4}}{-1}$$

$$x = \frac{3+2}{-1} \text{ or } \frac{3-2}{-1} = -5 \text{ or } -1$$

Note that these solutions correspond to the zeros in the graph and that they are symmetrical about the axis of symmetry.

- 2) Consider the function from the previous review example in which Philip tossed a rock that landed in the lake. In standard form, the function is represented by $h(t) = -16t^2 + 48t + 64$.
- Solve the equation $h(t) = 0$.
 - Solve the equation $h(t) = 80$.

Solution:

$$\text{a. } 0 = -16t^2 + 48t + 64$$

This function has a common factor of -16 : $0 = -16(t^2 - 3t - 4)$

$$0 = (t^2 - 3t - 4)$$

$$0 = (t-4)(t+1)$$

$$t = -1 \text{ or } t = 4 \text{ (seconds)}$$

The solution $t = 4$ corresponds with the solution found by reading the graph. Note that the solution $t = -1$ has no meaning in this problem situation.



Important Tip

When finding solutions to a quadratic equation that models a real-world situation, always check to make sure the solutions have meaning in the problem situation.

b. $80 = -16t^2 + 48t + 64$

$$0 = -16t^2 + 48t - 16$$

$$0 = t^2 - 3t + 1 \quad (\text{divide both sides by the common factor of } -16)$$

The expression $t^2 - 3t + 1$ does not factor, so apply the quadratic formula

$$x = \frac{-(-3) \pm \sqrt{(-3)^2 - 4(1)(1)}}{2(1)}$$

$$x = \frac{3 \pm \sqrt{5}}{2}, \text{ so } x = \frac{3 + \sqrt{5}}{2} \approx 2.6 \text{ seconds or } x = \frac{3 - \sqrt{5}}{2} \approx 0.4 \text{ seconds.}$$

Note that these solutions both have meaning in this problem situation. Moreover, they can be used to find an exact answer [$\sqrt{5}$ seconds] to the question in part e of that review example.

- 3) Complete the table below by stating whether each quadratic equation is factorable, the value of the discriminant, the number and character of the solutions, and the real solutions.

Equation	Factorable? Y/N	Value of discriminant	Number and character of solutions	Real solutions
$2x^2 - 10x + 12 = 0$				
$x^2 - 10x - 12 = 0$				
$x^2 + 6x + 10 = 0$				
$x^2 + 6x + 9 = 0$				

Solution:

Equation	Factorable? Y/N	Value of discriminant	Number and character of solutions	Real solutions
$2x^2 - 10x + 12 = 0$	Y $2(x-3)(x-2) = 0$	4	2 real solutions	$x = 2$ $x = 3$
$x^2 - 10x - 12 = 0$	N	52	2 real solutions	$x = 5 + \sqrt{13}$ $x = 5 - \sqrt{13}$
$x^2 + 6x + 10 = 0$	N	-4	0 real solutions	none
$x^2 + 6x + 9 = 0$	Y $(x+3)^2 = 0$	0	1 real solution	$x = -3$



Important Tip

When the value of the discriminant is a perfect square, the real solutions are rational.
When the value of the discriminant is 0, there is exactly 1 real solution.

EOCT Practice Items

1) What are the solutions to the equation $289 = \left(\frac{1}{3}x - 8\right)^2$?

- A. $x = -27$ only
- B. $x = 75$ only
- C. $x = -27$ and $x = 75$
- D. $x = -75$ and $x = 75$

[Key: C]

2) Use this graph of the function $g(x)$ to answer the question.

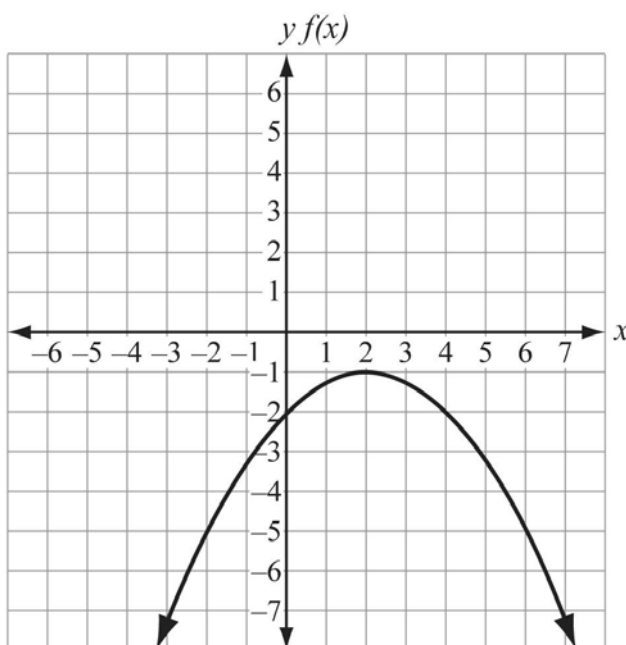

Which statement about the real solutions of $g(x)$ is true?

- A. $g(x)$ has no real solutions.
- B. $g(x)$ has exactly one real solution.
- C. $g(x)$ has two real solutions that are rational.
- D. $g(x)$ has two real solutions that are irrational.

[Key: A]

IMAGINARY AND COMPLEX NUMBERS



KEY IDEAS

1. The basis of the complex number system is the solution to the equation $x^2 = -1$. There is no real number that, when multiplied by itself, is equal to -1 . This problem was solved by defining the imaginary number i such that $i^2 = -1$; i.e., $i = \sqrt{-1}$.
2. For quadratic equations in which the value of the discriminant is less than 0, the solutions have the form $a \pm bi$, where a and b are real numbers and $i = \sqrt{-1}$. Such numbers are called *complex numbers*.

Example:

What are the solutions to the equation $x^2 + 6x + 10 = 0$?

Solution:

We already know from review example #3 in the preceding section that this equation has no real solutions. When we apply the quadratic formula, we get

$$x = \frac{-(6) \pm \sqrt{(6)^2 - 4(1)(10)}}{2(1)}, \text{ which can be simplified to}$$

$$x = \frac{-6 \pm \sqrt{-4}}{2} = -3 + \frac{\sqrt{-4}}{2} \text{ or } -3 - \frac{\sqrt{-4}}{2}.$$

Applying the rules of arithmetic with respect to square roots and using the definition of i , $\sqrt{-4} = (\sqrt{4})(\sqrt{-1}) = 2i$, allows the solutions to be simplified as

$$x = -3 + i \text{ or } x = -3 - i.$$



Important Tip

Complex solutions to quadratic equations will always have the form $x = a + bi$ or $x = a - bi$. The numbers $a + bi$ and $a - bi$ are known as a *conjugate pair*.

3. Arithmetic operations on complex numbers follow the same rules that apply to arithmetic operations on real numbers and algebraic expressions. For example, addition, subtraction, and multiplication work as follows.

- $(a + bi) + (c + di) = (a + c) + (b + d)i$; that is, to add (or subtract) complex numbers, add the real parts and then add the imaginary parts.
- $(a + bi)(c + di) = ac + (bc)i + (ad)i + (bd)i^2$. Since $i^2 = -1$, this expression can be simplified to $(ac - bd) + (bc + ad)i$.

Division of complex numbers makes use of the fact that ***the product of a complex number and its conjugate is a real number***. To divide complex numbers, multiply both the dividend and the divisor by the conjugate of the divisor, and then proceed according to the rules for multiplication and simplification of complex numbers.

$$\bullet \frac{(a + bi)}{(c + di)} = \frac{(a + bi)(c - di)}{(c + di)(c - di)} = \frac{(ac + bd) + (bc - ad)i}{c^2 - d^2i^2} = \frac{(ac + bd) + (bc - ad)i}{c^2 + d^2}$$

4. Any complex number can be represented as a point on a coordinate plane in which the horizontal axis represents the real part and the vertical axis represents the imaginary part. The ***absolute value*** of a complex number is defined as the distance of the point (a, b) from the origin. After applying the Cartesian distance formula, the absolute value of $a + bi$ is $\sqrt{a^2 + b^2}$.

REVIEW EXAMPLES:

- 1) What are the values of i^5 , i^{17} , and i^{265} ?

Solution:

All three expressions are equivalent to i .

- 2) Simplify the following expressions:

- $2i + 5i$
- $2i \times 5i$
- $5i \div 2i$
- $i\sqrt{15} \times i\sqrt{40}$

Solution:

- $7i$
- -10
- $\frac{5}{2}$
- $-10\sqrt{6}$

3) Simplify the following expressions:

- $(3 + 2i) + (15 - 8i)$
- $(3 + 2i) - (15 - 8i)$
- $(3 + 2i) \times (15 - 8i)$
- $(15 - 8i) \div (3 + 2i)$
- $(3 + 2i)^3$
- $(3 + 2i) \times (3 - 2i)$

Solution:

- $18 - 6i$
- $-12 + 10i$
- $61 + 6i$
- $\frac{29}{13} - \frac{54}{13}i$
- $-9 + 46i$
- 13

4) What is the absolute value of $(15 - 8i)$?

Solution:

The absolute value is 17.



Important Tip

As with all division problems, you can verify the result of division of complex numbers by multiplying the quotient by the divisor; the result should be the original dividend.

Using the complex numbers from review example 3d above,

$$\begin{aligned} \left(\frac{29}{13} - \frac{54}{13}i\right)(3 + 2i) &= \frac{87}{13} - \frac{162}{13}i + \frac{58}{13}i - \frac{108}{13}i^2 \\ &= \frac{195}{13} - \frac{104}{13}i = 15 - 8i \end{aligned}$$

EOCT Practice Item

Which expression is equivalent to $\frac{12-5i}{2-i}$?

- A. $\frac{19}{3} - \frac{22}{3}i$
- B. $\frac{29}{3} + \frac{2}{3}i$
- C. $\frac{19}{5} - \frac{22}{5}i$
- D. $\frac{29}{5} + \frac{2}{5}i$

[Key: D]

ARITHMETIC SERIES AND SUMS OF FINITE ARITHMETIC SERIES



KEY IDEAS

1. A **finite arithmetic series** is a series of numbers in which the difference between each term is constant and contains both a starting and ending term. For example, the series 1, 2, 3, 4, 5, ..., n is finite because the difference between each term and the next one is 1.
2. An arithmetic series can be defined in one of two ways: a **closed form** definition tells how to find the value of the n^{th} term. A **recursive** definition gives the first term and a formula for finding the $(n+1)^{\text{th}}$ term, given the value of the n^{th} term. Using the series from Key Idea #1 and defining T_n as the n^{th} term, a closed form definition would be $T_n = n$ and a recursive definition would be $T_{n+1} = T_n + 1$; $T_1 = 1$.
3. Many different real-life situations can be solved by finding the partial sum of the finite arithmetic series 1, 2, 3, 4, ..., n . The partial sum of the series is $1 + 2 + 3 + \dots + n$. The sum can be found by pairing the terms $(1+n) + (2+n-1) + (3+n-2) + \dots$. The value of

each term is equal to $(n + 1)$ and there are $\frac{n}{2}$ of them; hence the sum is $\frac{n(n+1)}{2}$. For an arithmetic series with a first term of t_1 and a last term of t_n , the sum is $\frac{n(t_1 + t_n)}{2}$.

The partial sums of other arithmetic series can be seen as translations of this one.

4. The square numbers $\{1, 4, 9, 16, 25, \dots\}$ are the partial sums of the arithmetic series of odd integers.

REVIEW EXAMPLES:

- 1) A university runs bus service to the following towns: Durham, Portsmouth, Lee, Dover, and Newington.
- How many routes are necessary if each route connects one of the towns with Durham?
 - How many routes are necessary if each route connects one of the towns with another, and there is a route that connects every pair of towns without having to go through Durham?
 - Suppose the university decides to add routes to two additional towns. How many additional routes will be necessary to meet the condition in part a? How many routes will be necessary to meet the conditions in part b?
 - Write a closed-form function, $R(t)$, that represents the number of necessary routes if there is service to t towns to meet the conditions in part b.

Solution:

- There are 4 towns other than Durham, so 4 routes are needed.
 - There are $4 + 3 + 2 + 1 = 10$ routes needed.
 - 2 more routes are needed to meet the condition in part a; $6 + 5 = 11$ more routes are needed to meet the conditions in part b.
 - $R(t) = \frac{t(t-1)}{2}$
- 2) Paul starts a new company that will build and sell guitars. His plan is to build 15 guitars the first month, 20 guitars the second month, and 25 guitars the third month. He plans to continue to increase the company's output by 5 guitars each month.
- What is the total number of guitars that Paul's company will build in the first year of production?
 - Paul plans to stabilize production when it reaches a level of 1000 guitars per month. How many years will it take to reach this level of production?
 - What is the total number of guitars that the company will have built when this point is reached?
 - Write a closed-form function, $G(n)$, that represents the total number of guitars that will have been built after n months of production.

Solution:

- a. $15 + 20 + 25 + \dots + 70 = 12 \left(\frac{70 + 15}{2} \right) = 510$ guitars
- b. The month in which 1000 guitars will be built is the solution of $10 + 5n = 1000$. The solution is 198 months or $16\frac{1}{2}$ years.
- c. $15 + 20 + 25 + \dots + 1,000 = 198 \left(\frac{15 + 1,000}{2} \right) = 100,485$ guitars
- d. $G(n) = n \left(\frac{15 + (10 + 5n)}{2} \right) = \frac{5}{2}n^2 + \frac{25}{2}n$

EOCT Practice Items

1) Which expression represents the sum of the first n multiples of 8?

- A. $8n$
B. $8n^2$
C. $4n^2 + 4n$
D. $8n^2 + 8n$

[Key: C]

2) Alex started a business making bracelets. She sold 30 bracelets the first month. Her goal is to sell 6 more bracelets each month than she sold the previous month.

If Alex meets her goal, what is the total number of bracelets she will sell in the first 12 months?

- A. 378
B. 426
C. 498
D. 756

[Key: D]

Unit 2 Right Triangle Trigonometry

This unit investigates the properties of right triangles. Relationships between side lengths and angle measures are explored, including properties of 30-60-90 and 45-45-90 triangles and the trigonometric ratios sine, cosine, and tangent.

KEY STANDARDS

MM2G1. Students will identify and use special right triangles.

- a. Determine the lengths of sides of 30°-60°-90° triangles.
- b. Determine the lengths of sides of 45°-45°-90° triangles.

MM2G2. Students will define and apply sine, cosine, and tangent ratios to right triangles.

- a. Discover the relationship of the trigonometric ratios for similar triangles.
- b. Explain the relationship between the trigonometric ratios of complementary angles.
- c. Solve application problems using the trigonometric ratios.

RIGHT TRIANGLE RELATIONSHIPS



KEY IDEAS

1. Right triangle relationships are all based on the fact that when one of the triangle congruence theorems applies, the relative measures of the angles and sides are fixed. For example, if the length of the hypotenuse and measure of one of the acute angles is known, any triangle with a hypotenuse of that length and an acute angle of that measure will be congruent by the HA theorem. As a result, the length of the other sides and the measures of the other angles can be determined.
2. All right triangles whose acute angles have measures of 30° and 60° are similar due to angle-angle-angle (AAA) similarity. In the case of a right triangle that has acute angles with measures of 30° and 60°, where s represents the length of the shorter of the two legs, the measures of the sides are as follows:
 - The length of the shorter leg is s .
 - The length of the longer leg is $s\sqrt{3}$.
 - The length of the hypotenuse is $2s$.

3. All right triangles whose acute angles have measures of 45° are similar as well. In the case of a right triangle with acute angles that both measure 45° , where s represents the length of each leg (note that, since the triangle is isosceles, the two legs are congruent), the measures of the sides are as follows:
- The length of each leg is s .
 - The length of the hypotenuse is $s\sqrt{2}$.
4. The trigonometric ratios *sine*, *cosine*, and *tangent* are defined as ratios of the lengths of the sides in a right triangle with a given acute angle measure. These terms are usually seen abbreviated as *sin*, *cos*, and *tan*.
- The *sine* of angle A is equal to the ratio $\frac{\text{length of opposite side}}{\text{length of hypotenuse}}$.
 - The *cosine* of angle A is equal to the ratio $\frac{\text{length of adjacent side}}{\text{length of hypotenuse}}$.
 - The *tangent* of angle A is equal to the ratio $\frac{\text{length of opposite side}}{\text{length of adjacent side}}$.
 - The tangent of angle A is also equivalent to $\frac{\sin A}{\cos A}$.



Important Tip

It is very important to commit these definitions to memory. Many people use the mnemonic “Soh Cah Toa” as a memory prompt.

5. The two acute angles of any right triangle are complementary. Relative to those two angles, the sides that are opposite and adjacent to a given angle are exchanged for the other angle. As a result, if angles P and Q are complementary, $\sin P = \cos Q$ and $\sin Q = \cos P$.

REVIEW EXAMPLES

- 1) The area of a square is 10 square centimeters. What is the product of the lengths of the diagonals of the square?

Solution:

Since the square has an area of 10 cm^2 , the side lengths can be found by solving $x^2 = 10$, where x represents the length of a side in centimeters. Since only the positive square root has meaning in this context, $x = \sqrt{10}$. The diagonals form angles of 45° with the sides so the length of each diagonal is $\sqrt{10} \cdot \sqrt{2} = \sqrt{20} = 2\sqrt{5}$ cm. The product of the lengths of the diagonals is therefore $2\sqrt{5} \cdot 2\sqrt{5} = 20 \text{ cm}^2$; i.e., the area of the square is equivalent to the half of the product of the lengths of the diagonals.

- 2) A parallelogram has sides that are 10 cm and 20 cm long. The measure of the acute angles of the parallelogram is 30° . What is the area of the parallelogram?

Solution:

The given information is illustrated in this graphic. To find the area of the parallelogram, we need the length of one of the sides, which was given, and the corresponding altitude, which is shown with a dashed line and labeled h .

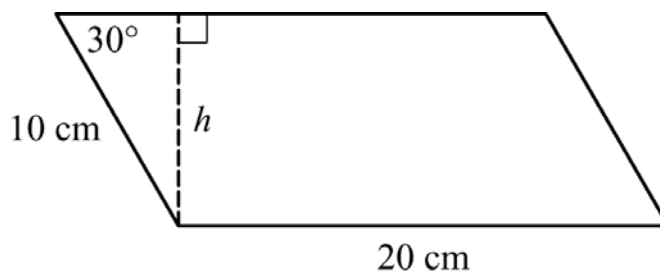

The altitude creates a right triangle in which the side that is 10 cm long is the hypotenuse. The altitude is the shorter of the two legs; therefore, its length is half the length of the hypotenuse, 5 cm. Thus, the area of the parallelogram is $20 \times 5 = 100 \text{ cm}^2$.

- 3) What is the area of a regular hexagon with sides that are 10 cm long?

Solution:

The given information is illustrated in this graphic. The point where all six small triangles share a vertex is the center of the hexagon. Note that the small triangles are all equilateral so the measure of the angles of the triangles is 60° . To find the area of a triangle, we will need to find the altitude. One altitude of a triangle is marked with a dashed line; the length of the altitude in centimeters is represented by h .

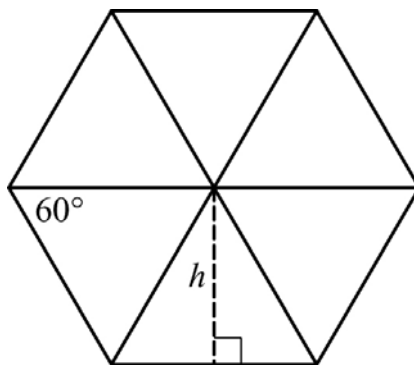

The altitude creates a 30-60-90 triangle in which the length of the hypotenuse is 10 cm and the length of the shorter leg is half of 10, or 5 cm. The altitude, h , is $\sqrt{3}$ times the length of the shorter leg, so $h = 5\sqrt{3}$. The area of each of the six equilateral triangles is $\frac{1}{2}(10)(5\sqrt{3}) = 25\sqrt{3}$; so the area of the hexagon is 6 times that amount, $150\sqrt{3}$ cm².

- 4) A road ascends a hill at an angle of 4° . For every 100 feet of road, how many feet does the road ascend?

Solution:

The given information is illustrated in this graphic. The vertical ascent is labeled v .

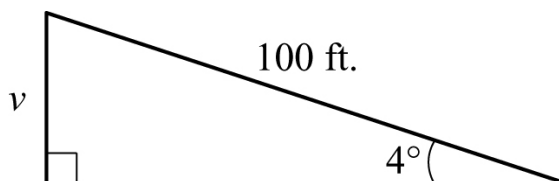

We need the ratio of the opposite side and the hypotenuse, so we will use the sine:

$$\sin(4^\circ) = \frac{v}{100} \rightarrow v = 100 \cdot \sin(4^\circ) = 6.976 \text{ feet.}$$

- 5) According to building codes, the maximum angle of ascent for a staircase in a home is 42.5° . To get from the first floor to the second floor in a new home, a staircase will have a total vertical distance of 115.5 inches. What is the minimum horizontal distance, to the nearest inch, needed for the staircase?

Solution:

The given information is illustrated in this graphic. The horizontal distance is labeled h .

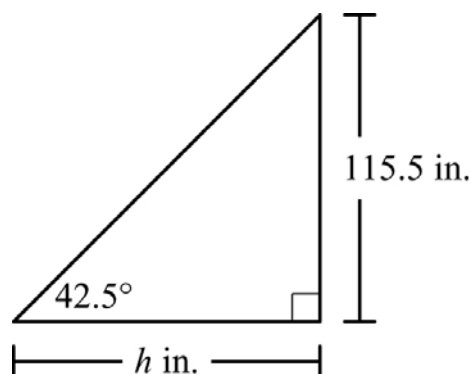

We need the ratio of the opposite side and the adjacent side, so we will use the tangent:

$$\tan(42.5^\circ) = \frac{115.5}{h} \rightarrow h = \frac{115.5}{\tan(42.5^\circ)} = 126 \text{ inches} = 10 \text{ feet, } 6 \text{ inches.}$$

EOCT Practice Items

- 1) The length of one diagonal of a rhombus is 12 cm. The measure of the angle opposite that diagonal is 60° .

What is the perimeter of the rhombus?

- A. 24 cm
- B. 48 cm
- C. $12\sqrt{3}$ cm
- D. $24\sqrt{3}$ cm

[Key: B]

- 2) Angle J and angle K are complementary angles in a right triangle. The value of $\tan J$ is $\frac{15}{8}$.

What is the value of $\sin J$?

- A. $\frac{8}{17}$
 B. $\frac{8}{15}$
 C. $\frac{15}{17}$
 D. $\frac{17}{15}$

[Key: C]

- 3) Triangle RST is a right triangle with right angle S , as shown.

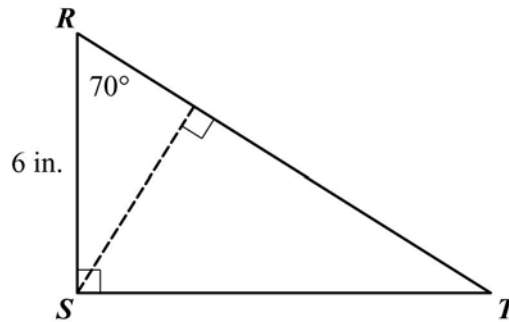

What is the area of triangle RST ?

- A. 6.15 sq. in.
 B. 6.54 sq. in.
 C. 46.47 sq. in.
 D. 49.45 sq. in.

[Key: D]

Unit 3 Circles and Spheres

This unit investigates the properties of circles and spheres. Properties of circles are used to solve problems involving arcs, angles, sectors, chords, tangents, and secants. The surface area and volume of spheres are also addressed.

KEY STANDARDS

MM2G3. Students will understand the properties of circles.

- a. Understand and use properties of chords, tangents, and secants as an application of triangle similarity.
- b. Understand and use properties of central, inscribed, and related angles.
- c. Use the properties of circles to solve problems involving the length of an arc and the area of a sector.
- d. Justify measurements and relationships in circles using geometric and algebraic properties.

MM2G4. Students will find and compare the measures of spheres.

- a. Use and apply surface area and volume of a sphere.
- b. Determine the effect on surface area and volume of changing the radius or diameter of a sphere.

PROPERTIES OF CIRCLES: CENTRAL ANGLES AND ARC MEASURES



KEY IDEAS

1. The measure of a minor arc of a circle is equal to the measure of the corresponding central angle.

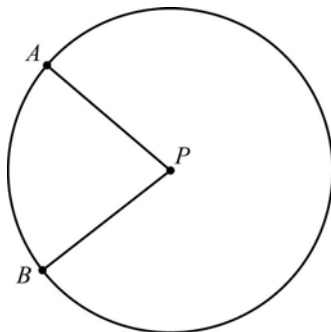

$$m\angle APB = m\widehat{AB}$$

2. The measure of an angle inscribed in a circle, that is, an angle that has its vertex on the circle, is half the measure of the corresponding minor arc, as shown below.

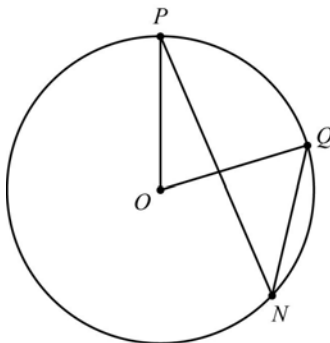

$$m\angle PNQ = \frac{1}{2} m\widehat{PQ}$$

$$m\angle POQ = m\widehat{PQ} = 2(m\angle PNQ)$$

3. An angle inscribed in a semicircle has a measure of 90° , as shown below.

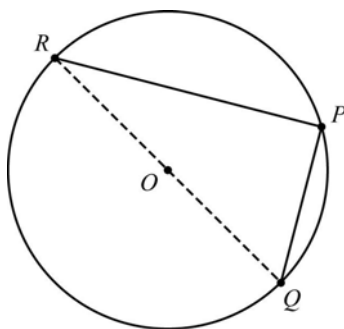

$$m\angle RPQ = \frac{1}{2} (m\widehat{RQ}) = \frac{1}{2} (180) = 90^\circ$$

REVIEW EXAMPLES

- 1) In this circle, what is the measure of $\angle PRQ$?

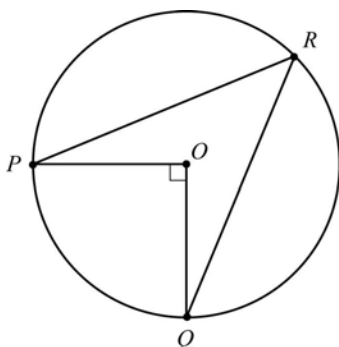

Solution:

The central angle, $\angle POQ$, is a right angle so $m\widehat{PQ} = 90^\circ$.

$$m\angle PRQ = \frac{1}{2}m\widehat{PQ} = 45^\circ.$$

Note that, regardless of where point R is located on the major arc \widehat{PQ} , $m\angle PRQ = 45^\circ$.

- 2) In Circle M below, $m\angle AMB = 50^\circ$ and \overline{AC} is a diameter. Find $m\widehat{AB}$, $m\widehat{ACB}$, and $m\widehat{BC}$.

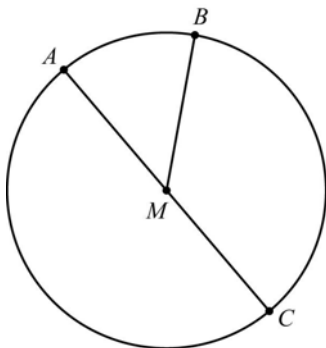

Solution:

Since $\angle AMB$ is a central angle and $m\angle AOB = 50^\circ$, $m\widehat{AB} = 50^\circ$

$$m\widehat{ACB} = 360 - m\widehat{AB} = 360 - 50 = 310^\circ.$$

Since \overline{AC} is a diameter, $m\widehat{AC} = 180^\circ$, so $m\widehat{BC} = 180 - 50 = 130^\circ$.

- 3) In Circle P below, \overline{AB} is a diameter.

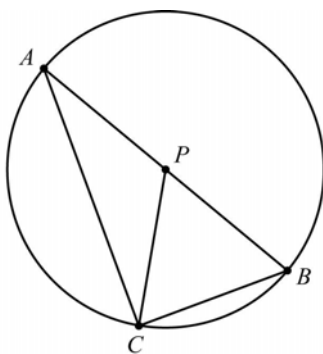

If $m\angle APC = 120^\circ$, find:

- $m\angle BPC$
- $m\angle BAC$
- $m\widehat{BC}$
- $m\widehat{AC}$

Solution:

- a. $\angle APC$ and $\angle CPB$ are supplementary, so $m\angle BPC = 180 - 120 = 60^\circ$.
- b. Triangle APC is an isosceles triangle, as two legs are formed by radii of the circle. Therefore the two base angles at points A and C are congruent.

$$m\angle BAC = \frac{1}{2}(180 - 120) = 30^\circ.$$

- c. $m\widehat{BC} = m\angle CPB = 60^\circ$ or $m\widehat{BC} = 2m\angle BAC = 2 \times 30 = 60^\circ$.
- d. $m\widehat{AC} = m\angle APC = 120^\circ$.

EOCT Practice Items

- 1) In circle O , \overline{PS} is a diameter. The measure of \widehat{PR} is 72° .

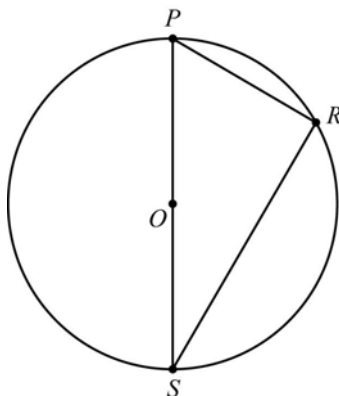

not drawn to scale

What is the measure of $\angle SPR$?

- A. 36°
 B. 54°
 C. 72°
 D. 108°

[Key: B]

2) Quadrilateral $WXYZ$ is inscribed in this circle.

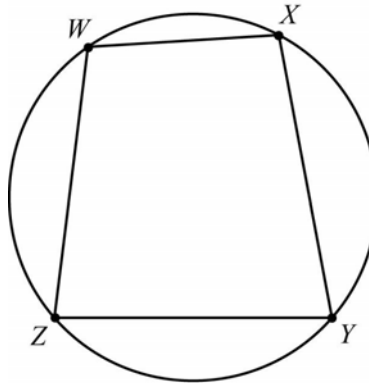

Which statement must be true?

- A. $\angle W$ and $\angle Y$ are complementary.
- B. $\angle W$ and $\angle Y$ are supplementary.
- C. $\angle Z$ and $\angle Y$ are complementary.
- D. $\angle Z$ and $\angle Y$ are supplementary.

[Key: B]

3) Isosceles triangle XYZ is inscribed in this circle.

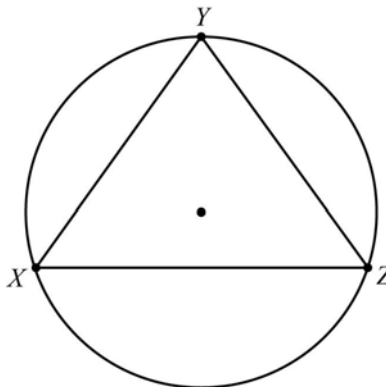

- $\overline{XY} \cong \overline{ZY}$
- $m\widehat{YZ} = 108^\circ$

What is the measure of $\angle XYZ$?

- A. 48°
- B. 54°
- C. 72°
- D. 108°

[Key: C]

PROPERTIES OF CIRCLES: TANGENTS, SECANTS, AND CHORDS



KEY IDEAS

1. A tangent line is perpendicular to the radius of a circle that meets it at the point of tangency, as shown below.

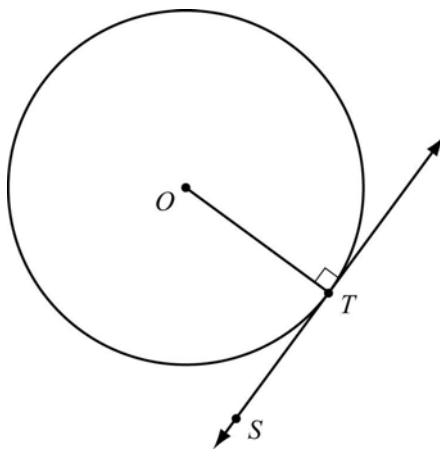

\overline{ST} is tangent to circle O at point T . $\overline{ST} \perp \overline{OT}$.

2. The perpendicular bisector of a chord passes through the center of the circle, as shown below.

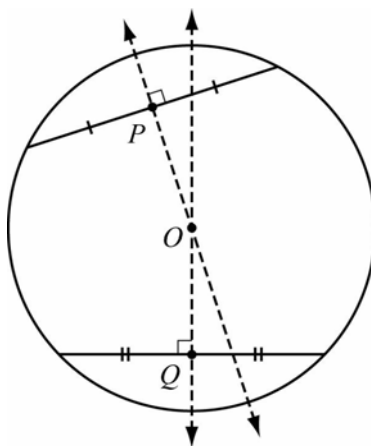

The perpendicular bisectors of each chord, \overline{OP} and \overline{OQ} , pass through O , the center of the circle.

3. If two chords intersect, the angles created have a measure that is equal to half of the sum of the corresponding arc measures, as shown in this circle.

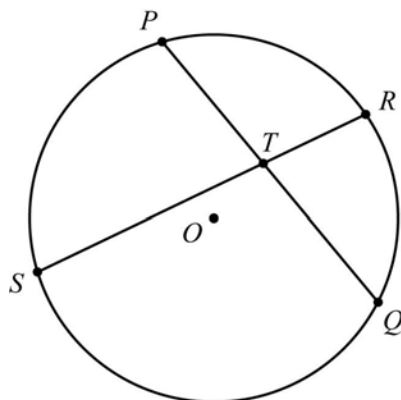

$$m\angle PTR = m\angle STQ = \frac{1}{2}(m\widehat{PR} + m\widehat{SQ})$$

$$m\angle PTS = m\angle RTQ = \frac{1}{2}(m\widehat{PS} + m\widehat{RQ})$$

4. The angle created by two secants or by a secant and a tangent has a measure that is equal to half the difference of the corresponding arc measures, as shown in these circles.

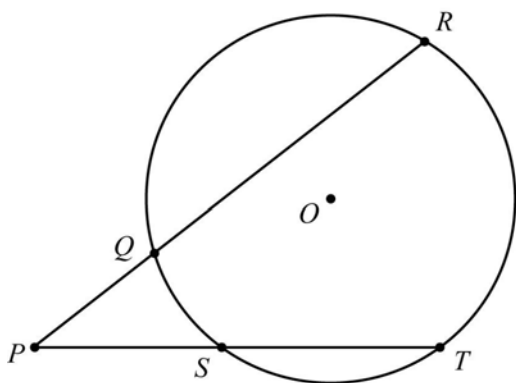

$$m\angle RPT = \frac{1}{2}(m\widehat{RT} - m\widehat{QS})$$

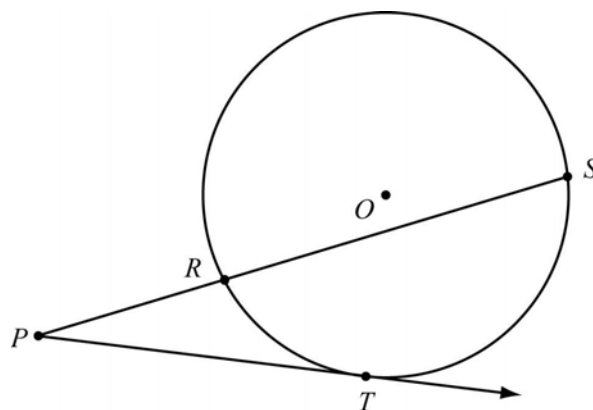

$$m\angle SPT = \frac{1}{2}(m\widehat{ST} - m\widehat{RT})$$

5. The angle created by a tangent and a chord has a measure that is equal to half the measure of its intercepted arc, as shown in this circle.

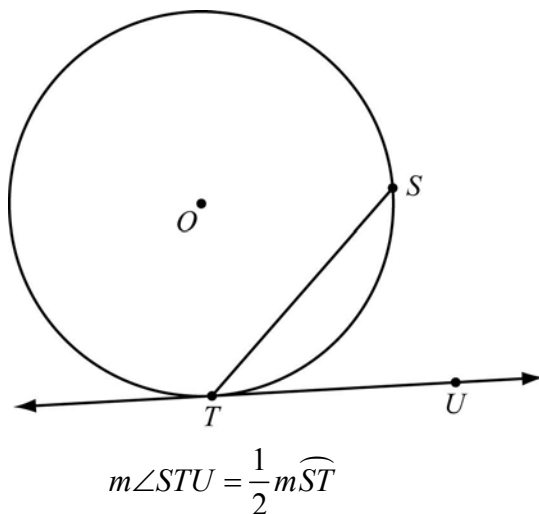

REVIEW EXAMPLES

- 1) Quadrilateral $UTSK$ is inscribed in a circle.

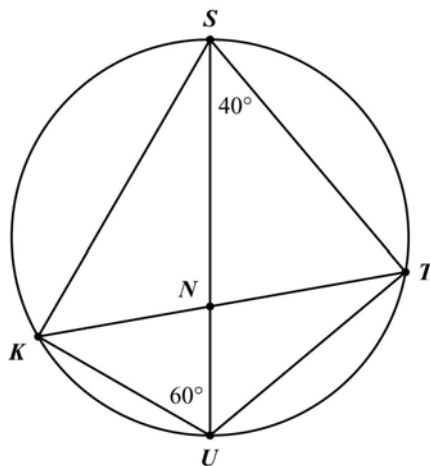

Find $m\widehat{KS}$ and $m\angle KNS$

Solution:

Minor arc \widehat{KS} is formed by chords \overline{US} and \overline{UK} . These chords also form $\angle KUS$.

$$m\widehat{KS} = 2m\angle KUS = 2 \times 60 = 120^\circ$$

$$m\widehat{TU} = 2m\angle TUS = 2 \times 40 = 80^\circ$$

$$m\angle KNS = \frac{1}{2}(m\widehat{KS} + m\widehat{TU}) = \frac{1}{2}(120 + 80) = 100^\circ$$

- 2) In the circle below, chords \overline{JM} and \overline{KN} are congruent. They intersect to form an angle with a measure of 72° . In addition, $m\widehat{MN} = 3m\widehat{JK}$.

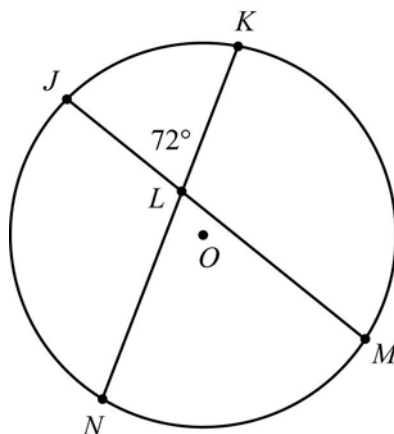

Find the measures of minor arcs \widehat{JK} , \widehat{MN} , \widehat{JN} , and \widehat{KM} .

Solution:

$m\angle JLK = \frac{1}{2}(m\widehat{MN} + m\widehat{JK})$; using the given information and letting x represent $m\widehat{JK}$, we

have $72 = \frac{1}{2}(3x + x) = \frac{1}{2}(4x) = 2x$, so $x = 36$.

Thus, $m\widehat{JK} = 36^\circ$ and $m\widehat{NM} = 3(36) = 108^\circ$.

Since $\overline{JM} \cong \overline{KN}$, $\widehat{JM} \cong \widehat{KN}$. Both arcs contain \widehat{JK} , so by subtracting the common arc from each $\widehat{JN} \cong \widehat{KM}$. If a set of arcs form a complete circle, the sum of their measures is 360° .

Hence, $m\widehat{JK} + m\widehat{KM} + m\widehat{MN} + m\widehat{NJ} = 360$, so $36 + m\widehat{KM} + 108 + m\widehat{NJ} = 360$. But

$m\widehat{JN} = m\widehat{KM}$, so this equation is equivalent to $144 + 2(m\widehat{KM}) = 360$.

$2(m\widehat{KM}) = 216$, so $m\widehat{KM} = m\widehat{JN} = 108^\circ$.

- 3) In circle O , \overline{PQ} is a diameter. Point S is on \overline{PQ} . \overline{SU} is tangent to circle O at point T . The measure of $\angle QTU$ is 60° .

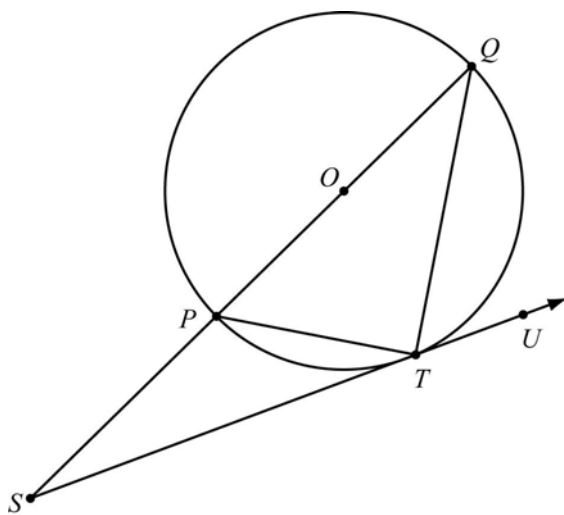

- Find $m\angle QPT$.
- Find $m\angle PQT$.
- Find $m\widehat{QT}$.
- Find $m\widehat{PT}$.
- Find $m\angle QSU$.
- Is it possible to construct this figure such that $m\angle QTU = 45^\circ$? Explain why or why not.

Solution:

- $\angle QPT \cong \angle QTU$ so $m\angle QPT = 60^\circ$.
- $\angle QTP$ is a right angle so $m\angle PQT = 90 - 60 = 30^\circ$.
- $m\widehat{QT} = 2(m\angle QPT) = 120^\circ$.
- $m\widehat{PT} = 2(m\angle PQT) = 60^\circ$.
- $m\angle QSU = \frac{1}{2}(m\widehat{QT} - m\widehat{PT}) = \frac{1}{2}(120 - 60) = 30^\circ$.
- If $m\angle QTU = 45^\circ$, then $m\angle QPT = 45^\circ$. Since $\angle QPT$ and $\angle TQP$ are complementary, then $m\angle TQP = 45^\circ$ as well. This means that $\angle TQP \cong \angle QTU$, making alternate interior angles congruent, $\overline{PQ} \parallel \overline{TU}$. But if $\overline{PQ} \parallel \overline{TU}$, point S cannot be on both of those lines. Therefore, it is not possible that $m\angle QTU = 45^\circ$.

EOCT Practice Items

- 1) In this diagram, segment \overline{QT} is tangent to circle P at point T .

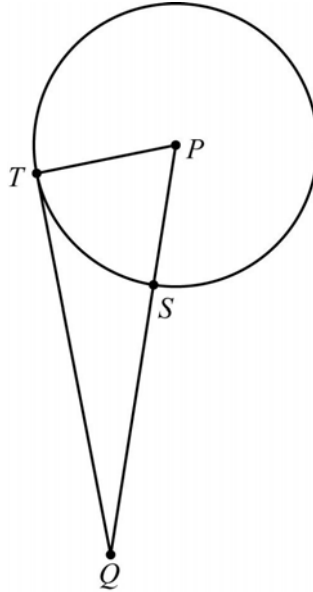

The measure of minor arc \widehat{ST} is 70° . What is $m\angle TQP$?

- A. 20°
- B. 25°
- C. 35°
- D. 40°

[Key: A]

2) Points R , S , T , and U lie on the circle. The measure of \widehat{RU} is represented by x .

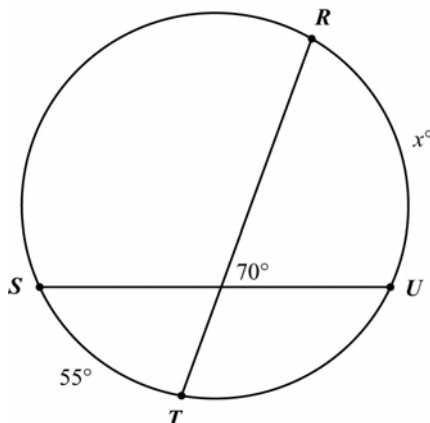

What is the value of x ?

- A. 70
- B. 85
- C. 110
- D. 140

[Key: B]

3) Points A , B , D and E lie on the circle. Point C is outside the circle.

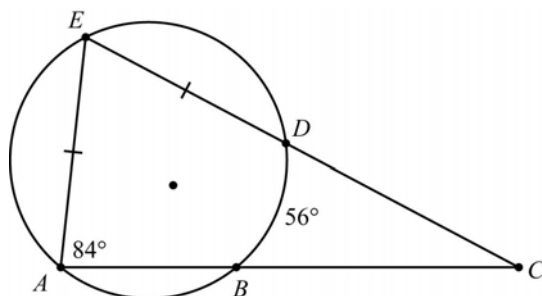

- $\overline{AE} \cong \overline{DE}$
- $m\widehat{BD} = 56^\circ$
- $m\angle EAC = 84^\circ$

What is the measure of $\angle ACE$?

- A. 28°
- B. 42°
- C. 56°
- D. 84°

[Key: A]

PROPERTIES OF CIRCLES: LINE SEGMENT LENGTHS



KEY IDEAS

- From a point outside the circle, the segments from that point to the points of tangency are congruent, as shown below.

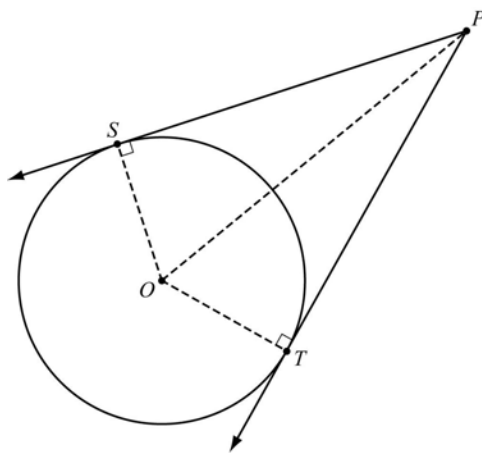

$\overline{SP} \cong \overline{TP}$. Note that $\triangle OSP \cong \triangle OTP$. As a result, $\overline{PT} \cong \overline{PS}$ and \overline{PO} bisects $\angle SPT$.

- Properties of other geometric figures (such as similar triangles, right triangles, or quadrilaterals) can be combined with properties of circles to find lengths of line segments.

REVIEW EXAMPLES

- A circle has a radius of 7 cm. Point P is located 18 cm outside the circle, with \overline{PT} and \overline{PS} tangent to the circle at points T and S , respectively. What are the lengths of \overline{PT} and \overline{PS} ?

Solution:

This figure illustrates the given information.

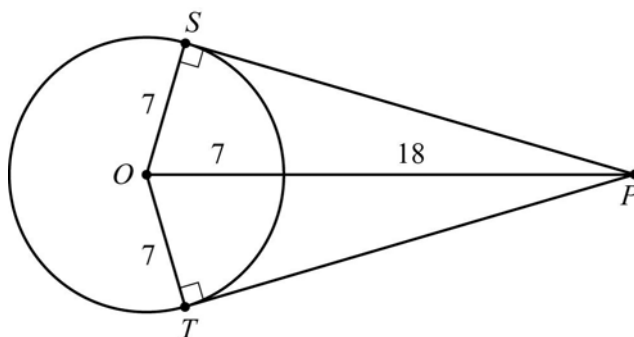

Since $\overline{PT} \perp \overline{OT}$ and $\overline{PS} \perp \overline{OS}$, triangles PSO and PTO are right triangles. The Pythagorean theorem can be used to find the lengths PT and PS :

$$PS = \sqrt{PO^2 - OS^2} = \sqrt{25^2 - 7^2} = \sqrt{625 - 49} = \sqrt{576} = 24.$$

Since $PS = PT$, both PT and PS are 24 cm.

- 2) The radius of circle O is 20 cm. Chord \overline{JK} is located 4 cm from the center of the circle. Chord \overline{RS} is located 10 cm from the center of the circle.
 - a. What are the lengths of chords \overline{JK} and \overline{RS} ?
 - b. What is the measure of $\angle ORS$?

Solution:

The circle below is a drawing of the situation described.

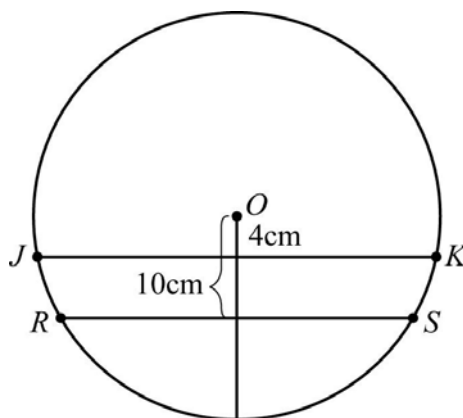

By forming triangles using the chords and the center of the circle, properties of right triangles can be used to find the lengths of the line segments.

Figures A and B illustrate the given information for each chord separately.

A.

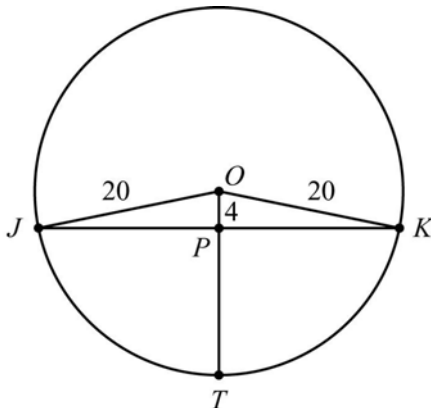

B.

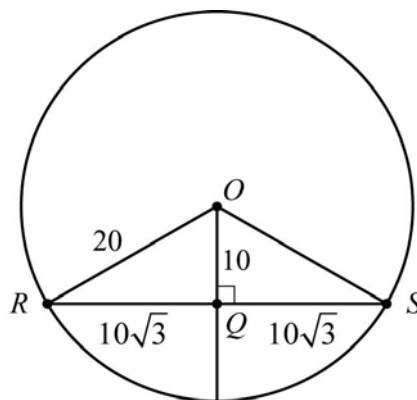

- a. Chords \overline{JK} and \overline{RS} are perpendicular to radius \overline{OT} , so the Pythagorean theorem can be used to find the lengths of JP and RQ :

$$JP = \sqrt{20^2 - 4^2} = \sqrt{384} = 8\sqrt{6}$$

$$RQ = \sqrt{20^2 - 10^2} = \sqrt{300} = 10\sqrt{3}$$

Radius \overline{OT} bisects the chords as well as being perpendicular to them, so

$$JK = 2(8\sqrt{6}) = 16\sqrt{6} \text{ and } RS = 2(10\sqrt{3}) = 20\sqrt{3}.$$

- b. The lengths of the sides of triangle ORQ have the relationship $s, s\sqrt{3}, 2s$. This means they form a 30-60-90 triangle. Angle ORS is opposite the shorter leg; therefore, $m\angle ORS = 30^\circ$.

3) Consider Circle O with a radius of r cm.

- If $r = 6$ cm, how far outside the circle is point P if the two tangents from P to circle O form an angle with a measure of 60° ?
- In terms of r , how far outside the circle is point P if the two tangents from P to circle O form an angle with a measure of 60° ?
- How far outside the circle is point P if the two tangents from P to circle O form an angle with a measure of 90° ?

Solution:

- a. The figure below illustrates circle O and point P with the angles described in part a.

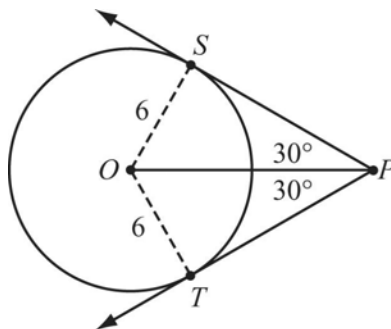

Triangle PSO is a 30-60-90 triangle. The length of the shorter leg is 6, so the length of \overline{OP} , the hypotenuse, is $2 \cdot 6 = 12$. The distance from P to the circle is $PO - 6 = 12 - 6 = 6$.

- b. The figure below illustrates circle O and point P with the angles described in part b.

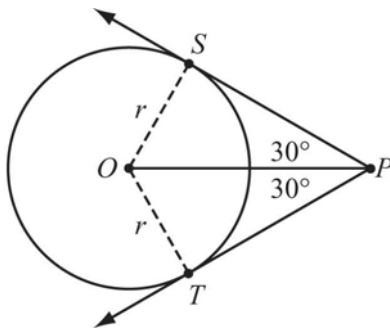

Triangle PSO is a 30-60-90 triangle. The length of the shorter leg is r , so the length of \overline{OP} , the hypotenuse, is $2r$. The distance from P to the circle is $PO - r = 2r - r = r$.

- c. The figure below illustrates circle O and point P with the angles described in part c.

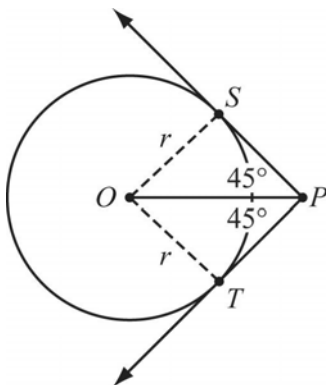

Triangle PSO is a 45-45-90 triangle. The length of a leg is r , so the length of \overline{OP} , the hypotenuse, is $r\sqrt{2}$. The distance from P to the circle is $PO - r = r\sqrt{2} - r = r(\sqrt{2} - 1)$.

EOCT Practice Items

- 1) The center of circle O is located at $(3, 4)$ on the coordinate plane. The radius of circle O is $\sqrt{3}$ units. Point P is located at $(7, 0)$.

What is the length of \overline{PT} , the segment from point P that is tangent to circle O at point T ?

- A. $\sqrt{13}$ units
- B. $\sqrt{19}$ units
- C. $\sqrt{29}$ units
- D. $\sqrt{35}$ units

[Key: C]

- 2) Points A , B , C , and D are on circle P as shown.

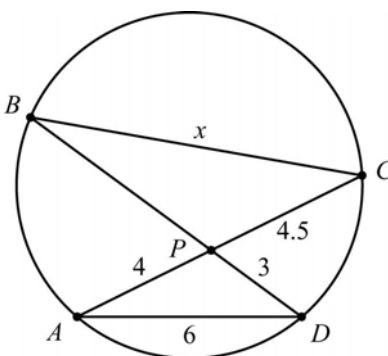

What is the value of x ?

- A. 7.5
- B. 8
- C. 9
- D. 12

[Key: C]

3) Quadrilateral $ABCD$ is a square in circle A .

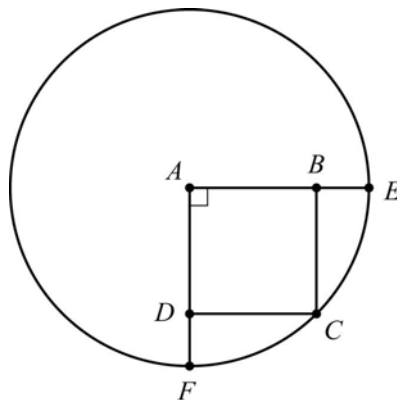

If $\overline{AE} = 3$ cm, what is the length of \overline{DF} ?

- A. $\sqrt{2}$
- B. $3 - 3\sqrt{2}$
- C. $\frac{3\sqrt{2}}{2}$
- D. $3 - \frac{3\sqrt{2}}{2}$

[Key: D]

PROPERTIES OF CIRCLES: ARC LENGTHS AND SECTOR AREAS



KEY IDEAS

1. The length of an arc that corresponds to a central angle with a measure of θ degrees in a circle with a radius r is $\frac{\theta}{360}$ times the circumference of the circle; i.e., $\frac{\theta}{360} \cdot 2\pi r = \frac{\theta\pi r}{180}$.
2. The area of a sector that corresponds to a central angle with a measure of θ degrees in a circle with a radius r is $\frac{\theta}{360}$ times the area of the circle; i.e., $\frac{\theta}{360} \cdot \pi r^2$.

REVIEW EXAMPLES

- 1) Triangle PQR is inscribed in circle O , as shown.

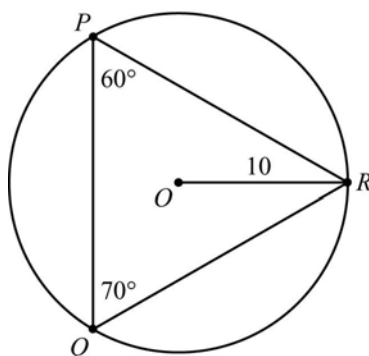

Find the lengths of the arcs \widehat{PR} , \widehat{RQ} , and \widehat{QP} .

Solution:

The measures of the arcs are twice the measures of the inscribed angles that correspond with each arc; i.e., $m\widehat{PR} = 2(70) = 140$, $m\widehat{RQ} = 2(60) = 120$, and $m\widehat{QP} = 2(50) = 100$.

The arc length of $\widehat{PR} = \frac{140}{360}(20\pi) = \frac{70\pi}{9}$.

The arc length of $\widehat{RQ} = \frac{120}{360}(20\pi) = \frac{20\pi}{3}$.

The arc length of $\widehat{QP} = \frac{100}{360}(20\pi) = \frac{50\pi}{9}$.

- 2) An equilateral triangle that has sides 10 cm long is inscribed in a circle. What is the area of the circle?

Solution:

The figure below illustrates the triangle and the circle. The center of the circle is located at point O .

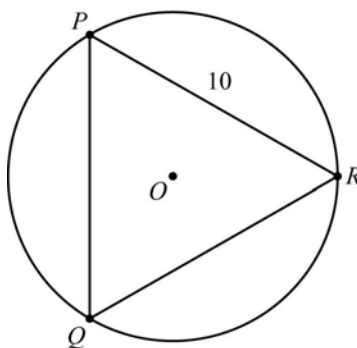

Since the sides of the triangle are all chords of circle O , point O is on the perpendicular bisectors of each of the sides of the triangle. The triangle is equilateral so the perpendicular bisectors are also the angle bisectors.

Let point M be the midpoint of side \overline{PR} . Triangle MOR is a 30-60-90 right triangle with a long leg that measures $\frac{10}{2} = 5$ cm. Radius \overline{OR} is the hypotenuse of that triangle, so

$$OR = 2\left(\frac{5}{\sqrt{3}}\right) = \frac{10}{\sqrt{3}}.$$

The area of circle O is $\pi r^2 = \pi\left(\frac{10}{\sqrt{3}}\right)^2 = \frac{100\pi}{3} = 33\frac{1}{3}\pi$.

3) In circle O , $\overline{PQ} \cong \overline{PR}$.

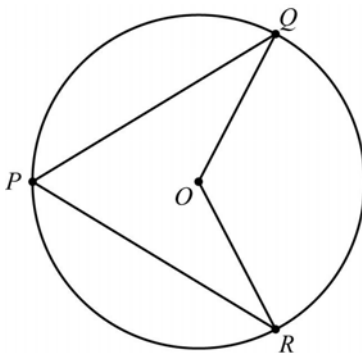

- a. If $m\widehat{QR} = 120^\circ$ and the radius of circle O is 20 cm, what is the area of sector QOR ?
- b. What is the area of quadrilateral $QPRO$?

Solution:

- a. The area of sector QOR is $\frac{120}{360} \times \pi(20)^2 = \frac{400\pi}{3}$.
- b. To find the area of the quadrilateral, start by drawing chord \overline{QR} with a midpoint at point T . Note that \overline{TO} is the perpendicular bisector of \overline{QR} and that, since $\overline{PQ} \cong \overline{PR}$, point P is on \overline{TO} as well.

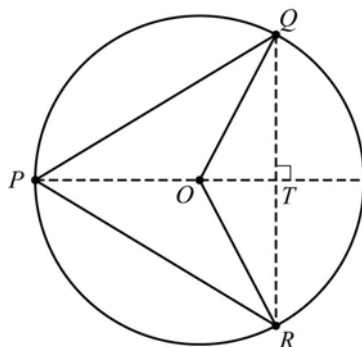

\overline{QT} is an altitude of triangle PQO , so by finding QT we can find the area of triangle PQO , which is half the area of quadrilateral $QPRO$.

Triangle QOT is a 30-60-90 triangle with a hypotenuse of 20 cm. \overline{QT} is the longer leg of that triangle, so $QT = \frac{20}{2}\sqrt{3} = 10\sqrt{3}$.

The area of $\triangle QOP = \frac{1}{2}(PO)(QT) = \frac{1}{2}(20)(10\sqrt{3}) = 100\sqrt{3}$, so the area of quadrilateral $QPRO = 2(100\sqrt{3}) = 200\sqrt{3}$.

EOCT Practice Items

- 1) A circular pizza with a diameter of 15 inches is cut into 8 equal slices. What is the area of one slice?
- A. 5.9 sq. in.
 B. 22.1 sq in.
 C. 88.4 sq. in.
 D. 120 sq. in.

[Key: B]

- 2) In this diagram, triangle OPQ is equilateral, with vertex O at the center of a circle and vertices P and Q on the circle.

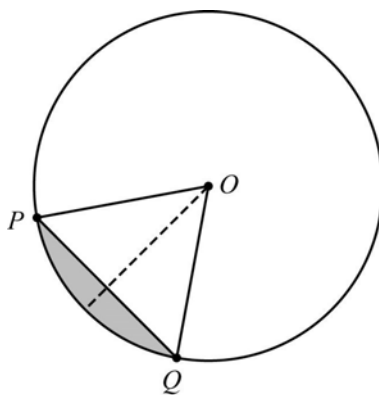

The radius of circle O is 12 cm. What is the area, in square units, of the shaded region?

- A. $24\pi - 18$
 B. $24\pi - 36\sqrt{3}$
 C. $48\pi - 18$
 D. $48\pi - 36\sqrt{3}$

[Key: B]

SURFACE AREA AND VOLUME OF SPHERES



KEY IDEAS

1. The surface area of a sphere with a radius r is given by $SA = 4\pi r^2$. The volume of the sphere is given by $V = \frac{4}{3}\pi r^3$.
2. Scale factors for linear dimensions, area, and volume state that if the ratio of the linear dimensions of two figures is $a : b$, then
 - the ratio of the areas is $a^2 : b^2$, and
 - the ratio of the volumes is $a^3 : b^3$.

REVIEW EXAMPLES

- 1) A sphere has a diameter of 10 meters.
 - a. What is the circumference of a great circle of the sphere?
 - b. What is the surface area of the sphere?
 - c. What is the volume of the sphere?
 - d. If the diameter is decreased by a factor of 10, how will it affect the circumference, surface area, and volume?

Solution:

- a. The circumference is 10π meters. Note that 10m is the **diameter**, not the radius, of the sphere.
- b. The surface area is $4\pi r^2 = 4\pi(5)^2 = 100\pi$ square meters.
- c. The volume is $\frac{4}{3}\pi r^3 = \frac{4}{3}\pi(5)^3 = \frac{500\pi}{3}$ cubic meters.
- d. The circumference will be decreased by a factor of 10, the surface area will be decreased by a factor of 100, and the volume will be reduced by a factor of 1000. [The resulting values would be π meters for the circumference, π square meters for the surface area, and $\frac{\pi}{6}$ cubic meters for the volume.]

- 2) The figure below represents half a sphere.

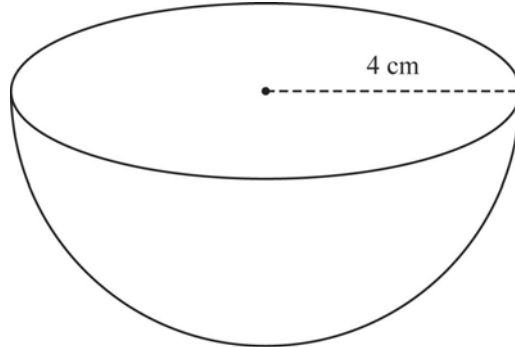

Find the surface area and volume of the figure.

Solution:

The surface area of *half* a sphere is $SA = \frac{1}{2} \times 4\pi r^2 = 2 \times \pi \times 4^2 = 32\pi = 100.53 \text{ cm}^2$

The volume of *half* a sphere is $V = \frac{1}{2} \times \frac{4}{3} \pi r^3 = \frac{2}{3} \times \pi \times 4^3 = 42.67\pi = 134.05 \text{ cm}^3$

EOCT Practice Items

- 1) A map company makes a globe in the shape of a sphere. The company plans to make a new model globe with a diameter that is 20% larger than the diameter of the original model.

By what percent will the surface area of the new model globe increase compared to the surface area of the original model?

- A. 4%
- B. 20%
- C. 40%
- D. 44%

[Key: D]

- 2) A sphere has a volume of 39π cubic centimeters. What is the surface area of the sphere?

- A. 3.0π sq. cm
- B. 9.5π sq. cm
- C. 38.0π sq. cm
- D. 81.5π sq. cm

[Key: C]

Unit 4 Statistics: Data Analysis

This unit investigates analysis and comparison of data sets using mean, standard deviation, and sampling techniques to estimate the mean and standard deviation of populations when the actual mean and standard deviation are not known.

KEY STANDARD

MM2D1. Using sample data, students will make informal inferences about population means and standard deviations.

- a. Pose a question and collect sample data from at least two different populations.
- b. Understand and calculate the means and standard deviations of sets of data.
- c. Use means and standard deviations to compare data sets.
- d. Compare the means and standard deviations of random samples with the corresponding population parameters, including those population parameters for normal distributions. Observe that the different sample means vary from one sample to the next. Observe that the distribution of the sample means has less variability than the population distribution.

UNDERSTANDING AND CALCULATING MEANS AND STANDARD DEVIATIONS



KEY IDEAS

1. The *mean* of a data set is the mathematical average of the data, which can be found by adding the data values and dividing the sum by the number of data values. The formula for

the *mean* with n data points is $\frac{\sum_{i=1}^n X_i}{n}$, where X_i is the i^{th} data point.

The mean is one of several measures of central tendency that can be used to describe a data set. Its main limitation is that, because every data point directly affects the result, it can be affected greatly by outliers. For example, consider these two sets of quiz scores:

Student P: {8, 9, 9, 9, 10}

Student Q: {3, 9, 9, 9, 10}

Both students consistently performed well on quizzes and both have the same **median** and **mode** score, 9. Student Q, however, has a mean quiz score of 8, while Student P has a mean quiz score of 9. Although many instructors accept the use of a mean as being fair and representative of a student's overall performance in the context of test or quiz scores, it can be misleading because it fails to describe the **variation** in a student's scores and the effect of a single score on the mean can be disproportionately large, especially when the number of scores is small.

2. The **mean absolute deviation** of a data set is the mean (or average) of the absolute differences (ignoring the sign) between each data value and the mean value for the set of

data. The formula for **mean absolute deviation** of a data set is $\frac{\sum_{i=1}^N |X_i - \bar{X}|}{N}$, where X_i is the i^{th} data point and \bar{X} is the mean value of the set of data. The absolute value is used to find the absolute difference, or the magnitude of the difference without respect to whether the difference is positive or negative.

This is a relatively simple way to describe the variation in a data set that was used in Mathematics I; it is simply the average value of the distance from the mean for each data point.

For the two students in Key Idea #1, the mean absolute deviations are as follows:

Student P: The mean score is 9. The mean absolute deviation is

$\frac{1+0+0+0+1}{5} = \frac{2}{5} = 0.4$. The average distance between the individual data values and the mean value is 0.4. This is a relatively small deviation meaning there is not a lot of variation in the data values.

Student Q: The mean score is 8. The mean absolute deviation is

$\frac{5+1+1+1+2}{5} = \frac{10}{5} = 2.0$. The average distance between the individual data values and the mean value is 2, which is relatively larger than the mean absolute deviation for student P. There is more variation in the scores for student Q than student P.

3. The **variance** of a data set is a measure to quantify the spread of data within a set. The

formula for **variance** of a data set is $\frac{\sum_{i=1}^N (X_i - \bar{X})^2}{N}$ or $\frac{1}{N} \sum_{i=1}^N (X_i - \bar{X})^2$, where X_i is the i^{th} data point, \bar{X} is the mean value of the data set, and N is the number of data points.

4. The **standard deviation** of a data set is the square root of the variance, i.e.,

$$\sigma = \sqrt{\frac{\sum_{i=1}^N (X_i - \bar{X})^2}{N}} = \sqrt{\frac{1}{N} \sum_{i=1}^N (X_i - \bar{X})^2}, \text{ where } X_i \text{ is the } i^{\text{th}} \text{ data point, } \bar{X} \text{ is the mean value of the data set, and } N \text{ is the number of data points.}$$

The standard deviation is more commonly used in statistics than the mean absolute deviation. Originally the preference was due to the use of the absolute value function in the formula for mean absolute deviation, which made calculations of this statistic more complicated than the calculation of the standard deviation. As technology has improved, making the differences in computation of the two statistics less complicated, the habit of using standard deviation as the preferred measure of spread has remained. Variance and standard deviation are the most common ways to describe variation in a data set.

Because the distance of each data point from the mean is squared, slightly more weight is given to data points that are farther from the mean than with the mean absolute deviation. However, in data that has a **normal distribution**, the majority of data points are relatively close to the mean.

For the two students in Key Ideas #1 and #2, the variance and standard deviation are as follows:

Student P: The variance is $\frac{1+0+0+0+1}{5} = \frac{2}{5} = 0.4$. The standard deviation is $\sqrt{0.4} = 0.63$.

Student Q: The variance is $\frac{25+1+1+1+4}{5} = \frac{33}{5} = 6.6$. The standard deviation is $\sqrt{6.6} = 2.57$.

5. A **normal distribution** is a set of data that follows a symmetrical, bell-shaped curve. Most of the data is relatively close to the mean. As the distance from the mean increases on both sides of the mean, the number of data points decreases. The **empirical rule** states that, for data that is distributed normally,
- approximately 68% of the data will be located within one standard deviation on either side of the mean;
 - approximately 95% of the data will be located within two standard deviations on either side of the mean; and
 - approximately 99.7% of the data will be located within three standard deviations on either side of the mean.



Important Tip

The extent to which a data set is distributed normally can be gauged by observing what percent of the data falls within one, two, or three standard deviations of the mean.

REVIEW EXAMPLES

- 1) Jesse is the manager of a guitar shop. He recorded the number of guitars sold each week for a period of 10 weeks. His data is shown in this table.

Week	1	2	3	4	5	6	7	8	9	10
# Guitars Sold	12	15	20	8	15	18	17	21	10	24

- What is the mean of Jesse's data?
- What are the variance and the standard deviation of Jesse's data?
- If an *outlier* is defined as any value that is more than two standard deviations from the mean, which, if any, values in Jesse's data would be considered an outlier?

Solution:

a. The mean is $\frac{(12 + 15 + 20 + 8 + 15 + 18 + 17 + 21 + 10 + 24)}{10} = \frac{160}{10} = 16$.

b. The variance is $\frac{(16 + 1 + 16 + 64 + 1 + 4 + 1 + 25 + 36 + 64)}{10} = \frac{228}{10} = 22.8$.

The standard deviation is $\sqrt{22.8} = 4.77$.

- c. $4.77 \times 2 = 9.54$, so any value less than $16 - 9.54 = 6.46$ or greater than $16 + 9.54 = 25.54$ is an outlier. There are no such values in Jesse's data.

- 2) Anne is the regional sales manager for a chain of guitar shops. She recorded the number of guitars sold at two stores in her region each week for one year (52 weeks). These histograms show the data Anne collected.

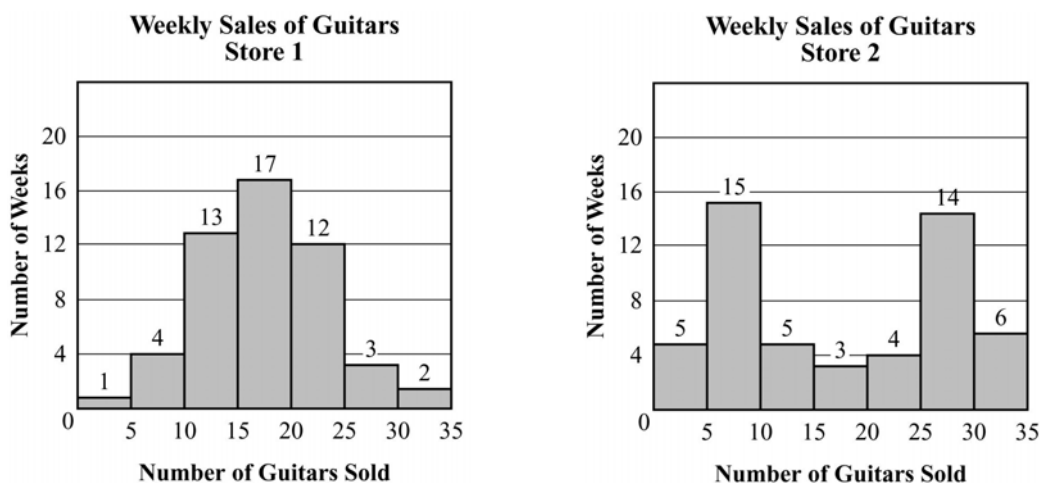

- Estimate the mean and standard deviation for each store.
- What is the range of possible means for each store?
- Explain why the empirical rule is or is not a good fit for each store.

Solution:

- Anne's data is presented in a histogram. A histogram shows the ranges into which data points fall, but it does not show individual data points. As a result, both the mean and standard deviation can be estimated but cannot be calculated exactly.

Because the data in each set is symmetrical, the best estimate for the mean is the value in the center of the whole range, 0 to 35, which is 17.5 for each data set.

One way to estimate the variance is to use the middle value in each range and the number of data points in that range. For example, at Store 1 there were 13 weeks in which the number of guitars sold was between 10 and 15. (For now, we won't consider which bar of the graph contains the boundary values 10 and 15.) The middle value of that range is 12.5. The distance of that value from the mean is 5, and the square of that value is 25. So, to calculate the variance, use 13×25 for those data points.

Using this technique, the estimated variance for Store 1 is

$$\frac{1 \times 225 + 4 \times 100 + 13 \times 25 + 17 \times 0 + 12 \times 25 + 3 \times 100 + 2 \times 225}{52} = \frac{2000}{52} = 38.46.$$

The estimated standard deviation is $\sqrt{38.46} = 6.20$.

Using the same technique for Store 2, the estimated variance is 107.69, and the estimated standard deviation is 10.38.

- b. To consider the range of possible means, we need to know what values are included in each bar. Assume here that each bar includes the boundary value to the right; i.e., the bar between 0 and 5 includes the value 5, and the bar between 5 and 10 includes 10 but not 5. In that case, the minimum possible mean would occur if every value in each bar was the least possible value for that bar. For Store 1, the least possible mean would be

$$\frac{1 \times 0 + 4 \times 6 + 13 \times 11 + 17 \times 16 + 12 \times 21 + 3 \times 26 + 2 \times 31}{52} = \frac{831}{52} = 15.98.$$

The greatest possible mean would be

$$\frac{1 \times 5 + 4 \times 10 + 13 \times 15 + 17 \times 20 + 12 \times 25 + 3 \times 30 + 2 \times 35}{52} = \frac{1040}{52} = 20.$$

Using the same strategy, the range of possible means for Store 2 is 15.90 to 20.00.

- c. The empirical rule is a good fit for the data for Store 1. The data is symmetrical and most are relatively close to the mean, with a decreasing amount of data as the distance from the mean increases. Using the estimated mean and standard deviation from part a, we would expect 68% of the data to be in the range 17.5 ± 5.4 ; i.e., 12.1 to 22.9, and 95% of the data to be in the range 17.5 ± 10.8 ; i.e., 6.7 to 28.3. Although we do not know the exact values for each week, based on the histogram it is reasonable to conclude that 68% of the weeks (35) fall between 12 and 23 guitars sold and 95% of the weeks (49) fall between 7 and 28 guitars sold.

Because the shape of the data distribution for Store 1 approximates a normal distribution, the standard deviation could have been estimated using the empirical rule. If the 35 weeks are within one standard deviation of the estimated mean, 17.5, it would include the 17 weeks in the 15–20 bar and 18 weeks in the 10–15 and 20–25 bars. Those 18 weeks would be split as 9 in each. Again, assuming a normal distribution, we would expect more of the data points in each bar to be closer to the mean, i.e., closer to 17.5, so it is reasonable to estimate that 9 of the data points in the 10–15 bar would have values of 12 or greater and, likewise, that 9 of the data points in the 20–25 bar would have values of 23 or less. This would make 12 one standard deviation less than the mean and 23 one standard deviation greater than the mean, so the estimated standard deviation would be $|12 - 17.5|$ or $|23 - 17.5|$, which is 5.5, very close to the standard deviation we estimated in part a.

For Store 2, the empirical rule is not a good fit. Although the data is symmetrical, it is not clustered about the mean as it is for Store 1. This type of data distribution is often called **bimodal** as there appears to be two modes, neither of which is close to the value of the mean or the median. Note that the exact median or mode cannot be determined from a histogram, as again the exact values of each data point are unknown.

EOCT Practice Items

- 1) This table shows the scores of the first six games played in a professional basketball league.

Winning Score	110	98	91	108	109	116
Losing Score	101	88	84	96	77	114

The winning margin for each game is the difference between the winning score and the losing score. What is the standard deviation of the winning margins for these data?

- A. 3.8 points
- B. 8.3 points
- C. 9.5 points
- D. 12.0 points

[Key: C]

- 2) This frequency table shows the heights for Mrs. Quinn's students.

Height (in inches)	Frequency
42	1
43	2
44	4
45	5
46	4
47	2
48	1

What is the approximate standard deviation of these data?

- A. 1.0 inches
- B. 1.5 inches
- C. 2.5 inches
- D. 3.5 inches

[Key: B]

SAMPLE MEANS AND DEVIATIONS



KEY IDEAS

1. **Samples** are typically used when it is impossible or impractical to collect data for an entire population. To improve the accuracy of the estimate, multiple samples can be drawn from the population. The mean and standard deviation of a set of sample means can be used to estimate the mean and standard deviation of a population when those actual values are not known. For a population with a mean of μ and a standard deviation of σ , the sample means will have a normal distribution with a mean of μ and a standard deviation of $\frac{\sigma}{\sqrt{n}}$, where n represents the number of elements in each sample and σ represents the population standard deviation. This means that, as the sample size increases, the amount of variance among the sample means decreases.

2. Because the population mean is estimated from the mean of a sample and the sample mean is used to calculate the estimated variance and standard deviation for the population, there is some additional variation introduced. For this reason, a better or **corrected** estimate of the standard deviation of the population from which a sample is drawn is given by using a denominator of $n - 1$ to calculate the standard deviation, i.e., the formula is

$$S = \sqrt{\frac{\sum_{i=1}^N (X_i - \bar{X})^2}{N-1}} = \sqrt{\frac{1}{N-1} \sum_{i=1}^N (X_i - \bar{X})^2}. \text{ This statistic is often called the } \mathbf{sample}$$

standard deviation because it is the standard deviation estimated from a sample.

3. The mean and standard deviation of the sample means can be used to estimate the mean and standard deviation of the population. If the mean of the sample means is \bar{X} and the standard deviation of the sample means is $S_{\bar{X}}$, the population mean can be estimated by using \bar{X} and the standard deviation can be estimated by using $S_{\bar{X}}\sqrt{n}$.

REVIEW EXAMPLE

Anne, the regional manager for the chain of guitar shops in the previous review example, took 10 random samples from her data about the number of guitars sold at each of the two shops per week during the last year. The sample means for each shop are as follows:

Shop 1: {21.25, 15.25, 25.0, 15.0, 14.0, 18.0, 12.25, 19.25, 22.0, 21.25}

Shop 2: {17.5, 18.25, 8.0, 22.25, 7.75, 18.25, 24.0, 28.5, 16.0, 16.25}

- What was the sample size that Anne used?
- What is the mean and corrected standard deviation for each set of samples?
- Use the sample mean and corrected standard deviation to estimate the mean and standard deviation for the entire year's data.

Solution:

- The sample means all come out to numbers that end in (have decimal parts of) .0, .5, .25, or .75. The sample mean is found by dividing the sum of the sample data points, which is an integer, by n , the sample size. A divisor of 4 would give the decimal parts above, so the sample size is 4. (Note: It is unlikely that a sample size of a multiple of 4 could also yield these sets of sample means as long as the samples are chosen at random and the data contains values that will form sums containing all the possible remainders when divided by n .)
- Using the formulas given in the previous section,
 - for the samples for Store 1, the mean is 18.325 and the corrected standard deviation is 4.11;
 - for the samples for Store 2, the mean is 17.675 and the corrected standard deviation is 6.46.
- Based on the information above, an estimate for the standard deviation of the weekly number of guitars sold for the entire year is $\sigma \times \sqrt{n}$. Because $n = 4$, $\sqrt{n} = 2$. Thus, for Store 1, the estimated standard deviation is 8.22, and for Store 2, the estimated standard deviation is 12.92.

**Important Tip**

While graphing calculator use is not allowed nor necessary on the EOCT, instructors are likely to use them for classroom experiences. When using a calculator or computer program to compute variance and standard deviation, it is important to know which formula is being used. On calculators such as the TI-84, the **corrected standard deviation**, or **sample standard deviation**, is given as S_x and the **uncorrected standard deviation**, or **population standard deviation**, is given as σ_x .

EOCT Practice Items

- 1) Kara took 10 random samples of the winning margins for each of two professional basketball teams. The sample size was 4. The distributions of the sample means are shown in these histograms.

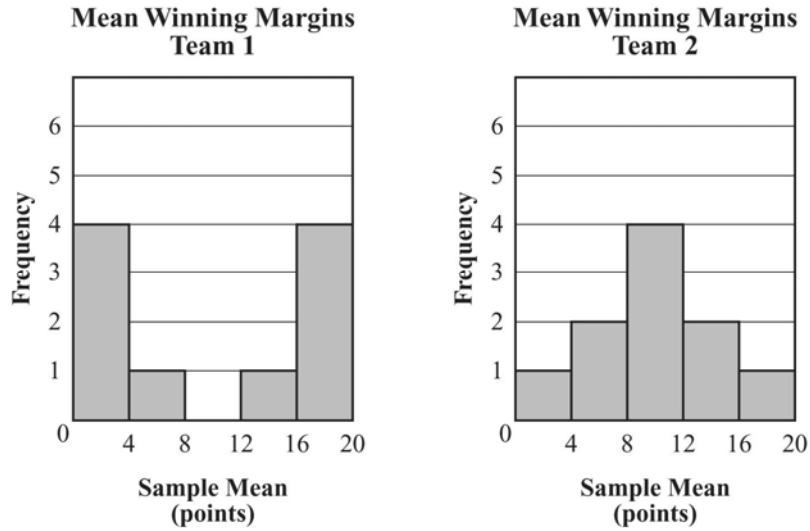

Which is the best estimate of the standard deviation for both samples?

- A. Team 1: 3.75 points; Team 2: 2.2 points
- B. Team 1: 7.4 points; Team 2: 4.4 points
- C. Team 1: 15 points; Team 2: 8.8 points
- D. Team 1: 10 points; Team 2: 10 points

[Key: B]

2) John took 10 random samples of the winning margins for each of two professional basketball teams. The distributions of the sample means are shown in these histograms.

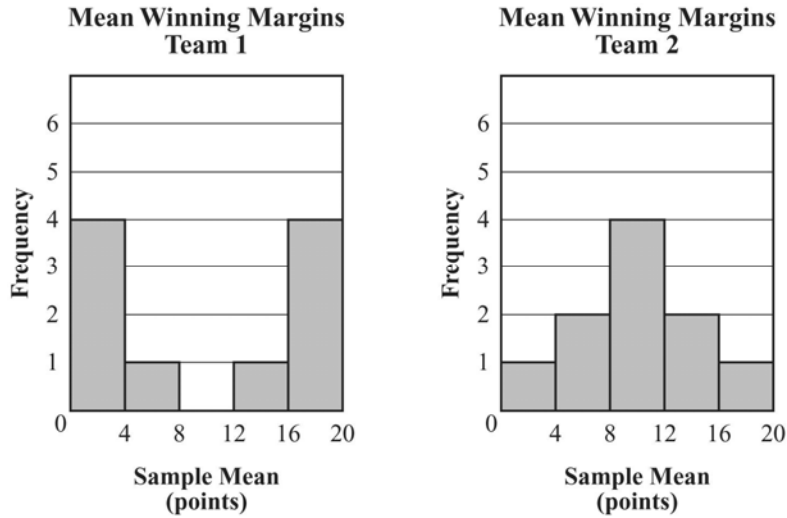

Based on John’s data, which statement is MOST likely true?

- A. Both the sample mean and the sample standard deviation are greater for Team 1 than for Team 2.
- B. The sample means for both teams are equal, but the sample standard deviation for Team 1 is greater.
- C. The sample means for both teams are equal, but the sample standard deviation for Team 2 is greater.
- D. Both the sample mean and the sample standard deviation are greater for Team 2 than for Team 1.

[Key: B]

- 3) Mary took 10 random samples of the winning margins for each of two professional basketball teams. The samples were taken from all 82 games in one season. The distributions of the sample means are shown in these histograms.

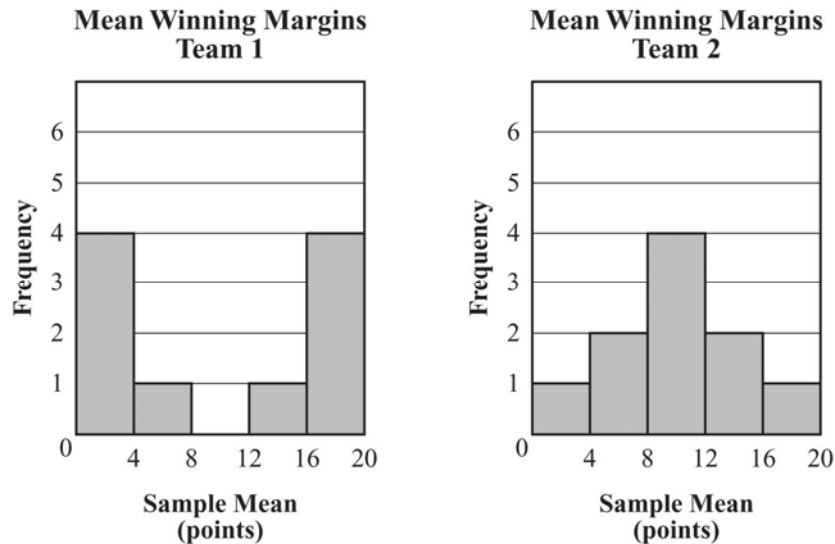

Which question can be answered based on Mary’s data?

- A. Which team had the greater number of all-star players?
- B. Which team won more games?
- C. Which team won by a more consistent margin?
- D. Which team lost more games by a narrow margin?

[Key: C]

- 4) In a set of 10 random samples of winning scores for games played in a professional basketball league, the sample size is 6, the sample mean is 97.5 points, and the sample standard deviation is 5.2 points. Which expression represents the estimated standard deviation of all the winning scores?

- A. $\frac{5.2}{\sqrt{10}}$
- B. $5.2\sqrt{10}$
- C. $\frac{5.2}{\sqrt{6}}$
- D. $5.2\sqrt{6}$

[Key: D]

Unit 5 Piecewise, Exponential, and Inverses

This unit investigates piecewise functions and their applications in a real-world context. Students study exponential functions and how they apply to business and science, as well as identify critical points and their interpretations. They solve simple equations by changing bases. The unit also explores inverses of functions and uses compositions to verify that functions are inverses of each other.

KEY STANDARDS

MM2A1. Students will investigate step and piecewise functions, including greatest integer and absolute value functions.

- a. Write absolute value functions as piecewise functions.
- b. Investigate and explain characteristics of a variety of piecewise functions including domain, range, vertex, axis of symmetry, zeros, intercepts, extrema, points of discontinuity, intervals over which the function is constant, intervals of increase and decrease, and rates of change.
- c. Solve absolute value equations and inequalities analytically, graphically, and by using appropriate technology.

MM2A2. Students will explore exponential functions.

- a. Extend properties of exponents to include all integer exponents.
- b. Investigate and explain characteristics of exponential functions, including domain and range, asymptotes, zeros, intercepts, intervals of increase and decrease, rates of change, and end behavior.
- c. Graph functions as transformations of $f(x) = a^x$.
- d. Solve simple exponential equations and inequalities analytically, graphically, and by using appropriate technology.
- e. Understand and use basic exponential functions as models of real phenomena.
- f. Understand and recognize geometric sequences as exponential functions with domains that are whole numbers.
- g. Interpret the constant ratio in a geometric sequence as the base of the associated exponential function.

MM2A5. Students will explore inverses of functions.

- a. Discuss the characteristics of functions and their inverses, including one-to-oneness, domain, and range.
- b. Determine inverses of linear, quadratic, and power functions and functions of the form $f(x) = xa$, including the use of restricted domains.
- c. Explore the graphs of functions and their inverses.
- d. Use composition to verify that functions are inverses of each other.

PIECEWISE FUNCTIONS



KEY IDEAS

1. **Piecewise functions** are functions that can be represented by more than one equation, with each equation corresponding to a different part of the domain. Piecewise functions do not always have to be line segments. The “pieces” could be pieces of any type of graph. This type of function is often used to represent real-life problems.

Example:

$$f(x) = \begin{cases} x+1, & \text{if } x < 1 \\ 2, & \text{if } 1 \leq x \leq 3 \\ (x-3)^2 + 2, & \text{if } x > 3 \end{cases}$$

To graph this piecewise function, graph the function $f(x) = x + 1$ for all values of x less than 1 or on the interval $(-\infty, 1)$; graph the function $f(x) = 2$ for all values of x from 1 to 3, including 1 and 3, or on the interval $[1, 3]$; and graph the function $f(x) = (x - 3)^2 + 2$ for all values of x greater than 3 or on the interval $(3, \infty)$.

This is the graph of the piecewise function in the example.

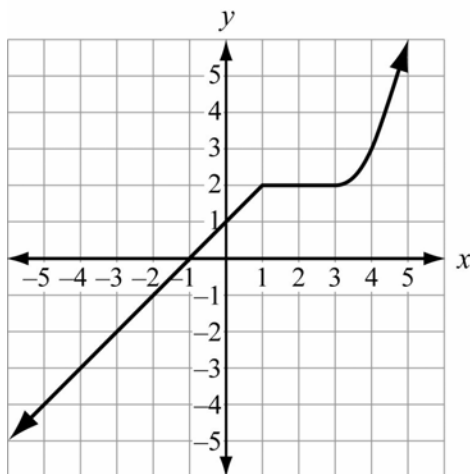

Notice that in this case the graph of the piecewise function is one continuous set of points because the individual graphs of each of the three pieces of the function connect. This is not true of all cases. The graph of a piecewise function may have a break or a gap where the pieces do not meet.

2. A **step function** is an example of a piecewise function.

Example:

$$f(x) = \begin{cases} 1, & \text{if } 0 < x \leq 2 \\ 2, & \text{if } 2 < x \leq 4 \\ 3, & \text{if } 4 < x \leq 6 \\ 4, & \text{if } 6 < x \leq 8 \end{cases}$$

This is a graph of the step function in the example.

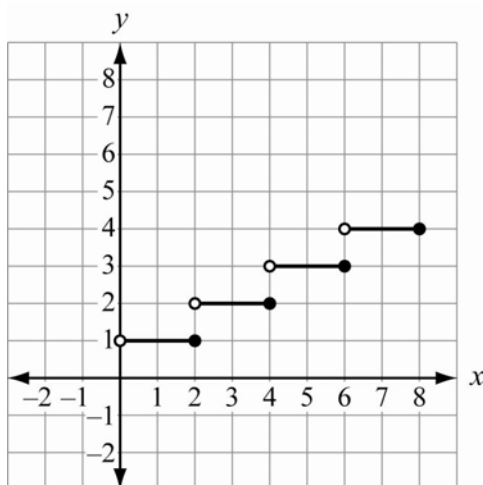

3. Two particular kinds of step functions are called **ceiling functions** ($f(x) = \lceil x \rceil$) and **floor functions** ($f(x) = \lfloor x \rfloor$). In a ceiling function, all nonintegers are rounded up to the nearest integer. An example of a ceiling function is when a phone service company charges by the number of minutes used and always rounds up to the nearest integer of minutes. In a floor function, all nonintegers are rounded down to the nearest integer. The way we usually count our age is an example of a floor function since we round our age down to the nearest year and do not add a year to our age until we have passed our birthday. The **floor function** is the same thing as the **greatest integer function** which can be written as $f(x) = \lceil x \rceil$ or $f(x) = \lfloor x \rfloor$.
4. An **absolute value function** is a special case of a piecewise function. The graph of an absolute value function makes a V-shape. The **vertex** of the graph is the point at the bottom of the V if the graph opens up, or the point at the top of the V if the graph opens down. The **axis of symmetry** of an absolute value function is the vertical line that passes through its vertex. For an absolute value function in the form $f(x) = a|x - h| + k$, the vertex is (h, k) and the line of symmetry is $x = h$.

Example:

We usually write an absolute value function as $f(x) = |x|$, but since absolute value is a measure of distance and distance is always positive, it also can be written as follows:

$$|x| = \begin{cases} x, & \text{if } x \geq 0 \\ -x, & \text{if } x < 0 \end{cases}$$

This is the graph of $f(x) = |x|$.

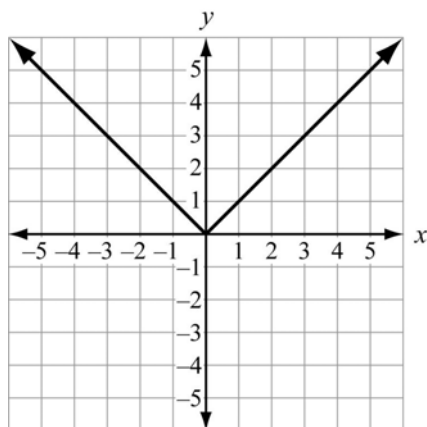

5. If the graph of the absolute value function from Key Idea #4 is shifted to the right 3 and up 2, it can be represented by the function $f(x) = |x - 3| + 2$.

This is the graph of the absolute value function $f(x) = |x - 3| + 2$.

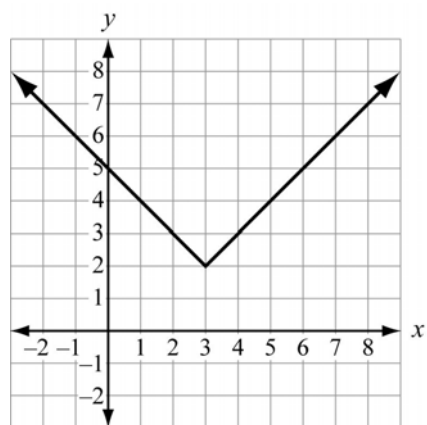

6. Remember that the **domain** of a function is the set of input numbers, and the **range** is the set of output numbers. In a piecewise function, the input number determines which equation to use to find the output number.

7. A function may have a **maximum** (highest point) and/or a **minimum** (lowest point) or neither. In an absolute value function, the vertex is at the maximum if the V opens down and at the minimum if the V opens up.
8. A **point of discontinuity** is a point where there is a break or a gap in the graph. A graph is said to be discontinuous when there is a break or a gap in it.

Example:

This is a graph of a piecewise function that is also a discontinuous function. It is discontinuous at $x = 2$.

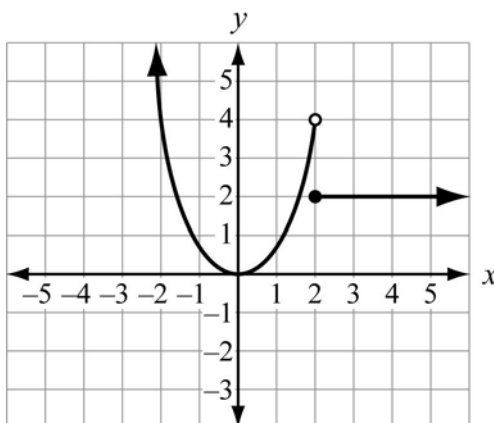

The open dot means that the point (2, 4) does not belong to the graph of the first piece. The closed dot means that the point (2, 2) belongs to the graph of the second piece. Notice that the function still passes the vertical line test. The vertical line $x = 2$ only passes through one point, (2, 2).

Example:

This is another graph of a piecewise function that is also a discontinuous function. It is discontinuous at $x = 0$. In this case, the function is **undefined** at $x = 0$.

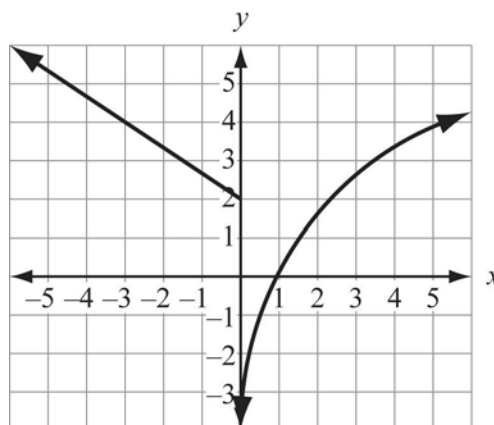

9. An interval for which a function is **constant** is the interval where the graph does not rise or fall. An interval for which a function **increases** is one where the function rises, while an interval for which a function **decreases** is one where the function falls. In other words, when the domain or the x -values of a function increases and the range or y -values increase, a function is said to increase. When the domain increases and the range decreases, a function is said to decrease.

Example:

This is a graph of a piecewise function that increases on the interval $x \leq 1$, decreases on the interval $x \geq 4$, and is constant on the interval $1 \leq x \leq 4$.

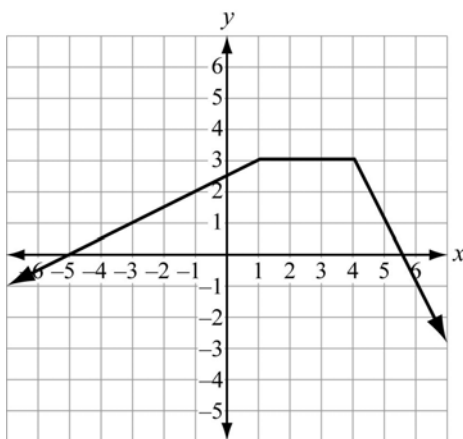

10. One way to solve an **absolute value equation** is to rewrite it as two linear equations and solve each equation. If the absolute value equation is complex, the first step is to isolate the expression containing the absolute value symbols. Always check each solution to be sure it works in the original equation.

Example:

In this case, the absolute value of the expression $3x - 4$ is given as 11. That means the value of $3x - 4$ must have a distance from zero of 11 units, which can be in a positive or negative direction. When we rewrite it as two linear equations, we set the expression equal to 11 and then set it equal to -11 . It is written as a disjunction using the word “or.”

$$|3x - 4| = 11$$

$$3x - 4 = 11 \quad \text{or} \quad 3x - 4 = -11$$

$$3x = 15 \quad \text{or} \quad 3x = -7$$

$$x = 5 \quad \text{or} \quad x = -\frac{7}{3}$$

11. Another way to solve an absolute value equation is to graph it on a coordinate grid.

Example:

To solve $|x - 4| = 3$ by graphing, first rewrite it as $f(x) = |x - 4|$. Graph the function. The solution would be the x -values when the y -values are 3.

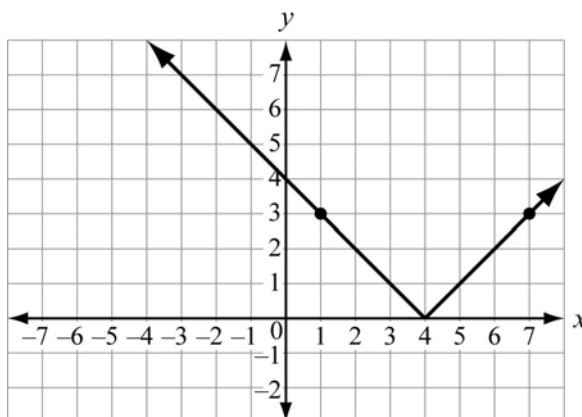

By looking at the graph, you can see that the solutions or the x -values when the y -values are 3 would be $x = 1$ or $x = 7$.

12. One way to solve an **absolute value inequality** in the form $|ax + b| < c$ or $|ax + b| \leq c$ is to rewrite it as a compound inequality.

Example:

In this case, the absolute value of the expression $2x + 5$ is given as being less than 13. This means that the value of $2x + 5$ must have a distance from zero of less than 13 units, which can be in a positive direction or a negative direction. Therefore we write it as a conjunction and solve it.

$$\begin{aligned} |2x + 5| &< 13 \\ -13 &< 2x + 5 < 13 \\ -18 &< 2x < 8 \\ -9 &< x < 4 \end{aligned}$$

The solution can be any real number between -9 and positive 4 . This is the graph of the absolute value inequality on a number line.

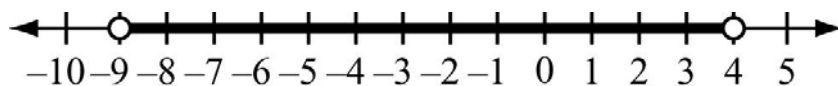

13. Another way to solve an absolute value inequality in the form $|ax + b| < c$ or $|ax + b| \leq c$ is to graph it on a coordinate grid.

Example:

To solve $|x + 3| < 4$ by graphing, first rewrite it as $f(x) = |x + 3|$. Graph the function. The solution would be all of the x -values when the y -values are less than 4.

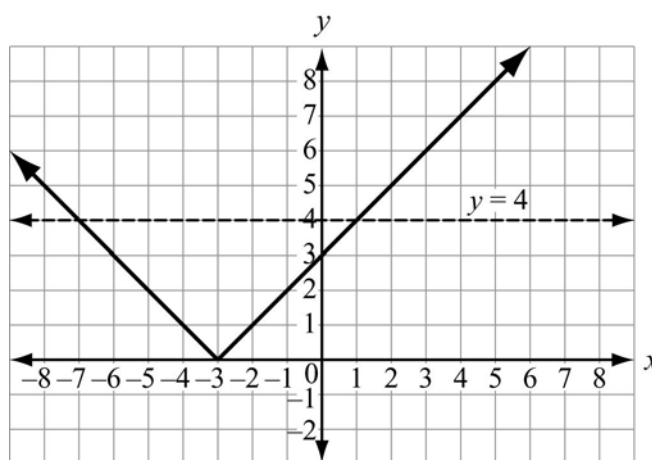

A dotted line is drawn across the graph at $y = 4$. All of the x -values on the graph that are below or less than the dotted line are solutions. The solution is the set of all real numbers greater than -7 and less than 4 , or $-7 < x < 4$.

14. One way to solve an **absolute value inequality** in the form $|ax + b| > c$ or $|ax + b| \geq c$ is to rewrite it as a disjunction and solve each part of the disjunction.

Example:

In this case, the absolute value of the expression $2x + 5$ is given as being greater than 13. This means that the value of $2x + 5$ must have a distance from zero of more than 13 units, which can be in a positive direction or a negative direction. There we write it as a disjunction and solve it as shown.

$$|2x + 5| > 13$$

$$2x + 5 < -13 \quad \text{or} \quad 2x + 5 > 13$$

$$2x < -18 \quad \text{or} \quad 2x > 8$$

$$x < -9 \quad \text{or} \quad x > 4$$

This is the graph of the absolute value inequality on a number line.

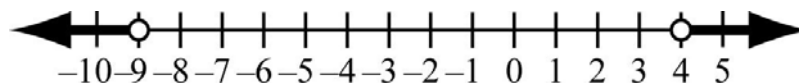

15. Another way to solve an inequality in the form $|ax + b| > c$ or $|ax + b| \geq c$ is to graph it on a coordinate grid.

Example:

To solve $|x + 1| > 2$ by graphing, first rewrite it as $f(x) = |x + 1|$. Graph the function. The solution would be all of the x -values when the y -values are greater than 2.

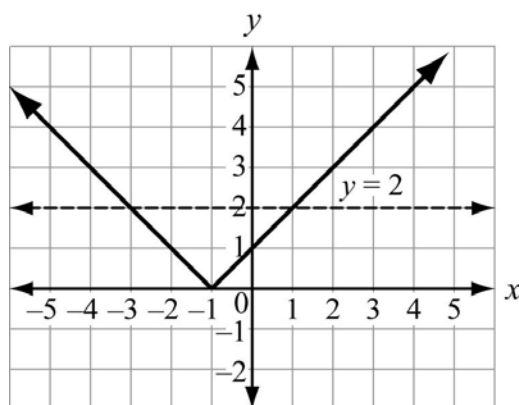

A dotted line is drawn across the graph at $y = 2$. All of the x -values on the graph that are above or greater than the dotted line are solutions. The solution is the set of all real numbers greater than 1 or less than -3 , or the solution can be written as $x > 1$ or $x < -3$.

REVIEW EXAMPLES

- 1) A coordinate grid represents a rectangular pool table. A ball is on a pool table at the point $(2, 3)$. The ball is rolled so that it hits the side of the pool table at the point $(9, 10)$. Then it rolls toward the other side, as shown in this diagram.

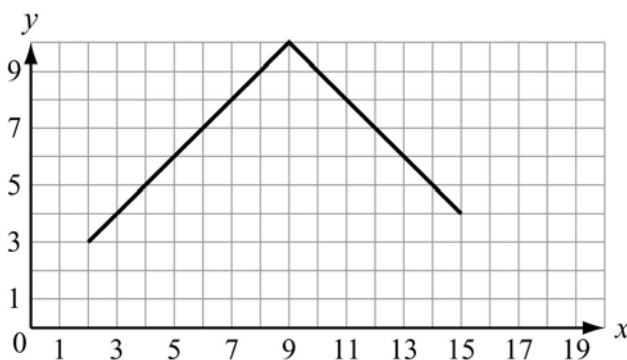

- Write a piecewise function that can represent the path of the ball.
- If the ball continues to roll, at what point will it hit the other side of the pool table?
- What do the x -value and the y -value represent?

Solution:

- a. To find a function that can represent the path of the ball, notice that the path of the ball forms a V. That means it can be represented by an absolute value function. Identify the vertex as point (9, 10). The slope (rise over run) is 1, and since the V opens down, a or the slope of the function is -1 . Substitute this information into the absolute value function formula $f(x) = a|x - h| + k$. The function is $f(x) = -|x - 9| + 10$.

This can be written as a piecewise function so that it represents only the part of the path shown in the diagram that the ball actually traveled.

$$f(x) = \begin{cases} x + 1, & \text{if } 2 \leq x < 9 \\ -x + 19, & \text{if } 9 \leq x \leq 15 \end{cases}$$

To write the piecewise function from $f(x) = -|x - 9| + 10$, follow these steps:

If $x - 9 \geq 0$,

then $|x - 9| = x - 9$

$$\text{so } f(x) = -(x - 9) + 10$$

$$f(x) = -x + 9 + 10$$

$$f(x) = -x + 19$$

If $x - 9 < 0$,

then $|x - 9| = -(x - 9)$

$$\text{so } f(x) = -(-(x - 9)) + 10$$

$$f(x) = -(-x + 9) + 10$$

$$f(x) = x - 9 + 10$$

$$f(x) = x + 1$$

The interval is determined by looking at the graph for the actual path of the ball.

For $f(x) = x + 1$, the interval is $2 \leq x < 9$, and for $f(x) = -x + 19$, the interval is $9 \leq x \leq 15$.

- b. The ball will hit the other side at (19, 0).
- c. The x -value represents the distance to the right of the diagram of the pool table, and the y -value represents the distance up from the bottom of the diagram of the pool table.
- 2) A computer repair person charges \$80 per hour for labor. She charges her labor in increments of 15 minutes. For example, if she works for 39 minutes, she rounds up to 45 minutes and charges \$60.
- a. Write a function to represent the amount the repair person charges up to and including 90 minutes of labor.
- b. Graph the function from part a. Let x represent the number of minutes of labor charged.

Solution:

$$a. \quad f(x) = \begin{cases} 20, & \text{if } 0 < x \leq 15 \\ 40, & \text{if } 15 < x \leq 30 \\ 60, & \text{if } 30 < x \leq 45 \\ 80, & \text{if } 45 < x \leq 60 \\ 100, & \text{if } 60 < x \leq 75 \\ 120, & \text{if } 75 < x \leq 90 \end{cases}$$

b.

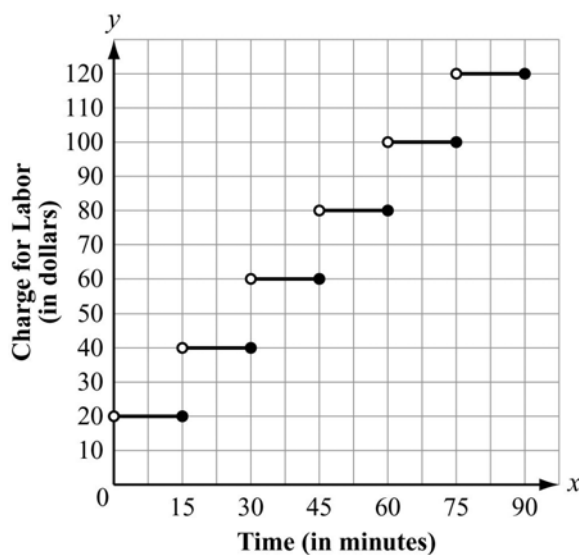
**EOCT Practice Items**1) Which function is equivalent to $f(x) = 2|x + 2| + 1$?

- A. $f(x) = \begin{cases} 2x + 5, & \text{if } x \geq -2 \\ -2x - 3, & \text{if } x < -2 \end{cases}$
- B. $f(x) = \begin{cases} 2x + 5, & \text{if } x \geq 1 \\ -2x - 3, & \text{if } x < 1 \end{cases}$
- C. $f(x) = \begin{cases} -2x - 5, & \text{if } x \geq -2 \\ 2x + 3, & \text{if } x < -2 \end{cases}$
- D. $f(x) = \begin{cases} -2x - 5, & \text{if } x \geq 1 \\ 2x + 3, & \text{if } x < 1 \end{cases}$

[Key: A]

- 2) What is the function that results from multiplying $f(x) = |x|$ by -1 and shifting it 2 units to the right?

- A. $f(x) = \begin{cases} -x - 2, & \text{if } x \leq 2 \\ x + 2, & \text{if } x > 2 \end{cases}$
- B. $f(x) = \begin{cases} -x - 2, & \text{if } x \leq 0 \\ x + 2, & \text{if } x > 0 \end{cases}$
- C. $f(x) = \begin{cases} x - 2, & \text{if } x \leq 2 \\ -x + 2, & \text{if } x > 2 \end{cases}$
- D. $f(x) = \begin{cases} x - 2, & \text{if } x \leq 0 \\ -x + 2, & \text{if } x > 0 \end{cases}$

[Key: C]

- 3) This graph shows the two parts of a piecewise function.

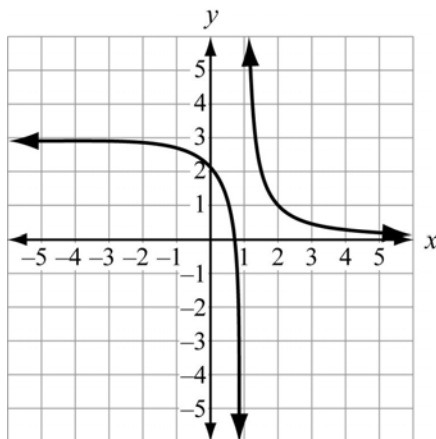

For what value of x is the function NOT defined?

- A. -1
- B. 0
- C. 1
- D. 2

[Key: C]

EXPONENTIAL FUNCTIONS



KEY IDEAS

1. There are five basic *properties of exponents*:

a. $a^n a^m = a^{n+m}$

Example:

$$2^3 \cdot 2^5 = 2^{3+5} = 2^8 = 256$$

b. $(a^n)^m = a^{n \cdot m}$

Example:

$$(3^2)^3 = 3^{2 \cdot 3} = 3^6 = 729$$

c. $a^0 = 1$

Example:

$$5^0 = 1$$

d. $\frac{a^n}{a^m} = a^{n-m}$

Example:

$$\frac{2^5}{2^3} = 2^{5-3} = 2^2 = 4$$

e. $a^{-n} = \frac{1}{a^n}$

Example:

$$3^{-2} = \frac{1}{3^2} = \frac{1}{9}$$

Example:

$$\left(\frac{1}{4}\right)^{-2} = \left(\frac{4}{1}\right)^2 = 4^2 = 16$$

Example:

$$\frac{2^3}{2^5} = 2^{3-5} = 2^{-2} = \frac{1}{2^2} = \frac{1}{4}$$

2. The properties of exponents can be used to solve exponential equations. The first step is to rewrite the equation so that the bases on both sides of the equation are the same. If the bases on both sides are the same, then the exponents must be equal.

Example:

$$25^{x-2} = 125^{4x}$$

$$(5^2)^{x-2} = (5^3)^{4x}$$

$$5^{2(x-2)} = 5^{3(4x)}$$

$$5^{2x-4} = 5^{12x}$$

Now that the bases are the same, the exponents are equal.

$$2x - 4 = 12x$$

$$10x = -4$$

$$x = -\frac{2}{5}$$

3. An **exponential function** with a base b is written $f(x) = b^x$, where b is a positive number other than 1.
4. An **exponential growth function** can be written in the form $f(x) = ab^x$, where $a > 0$ and $b > 1$. An **exponential decay function** can be written in the form $f(x) = ab^x$, where $a > 0$ and $0 < b < 1$.

Example:

The function $f(x) = 2^x$ is an **exponential growth function**. This is a table of values for the function.

x	$f(x)$
-3	$\frac{1}{8}$
-2	$\frac{1}{4}$
-1	$\frac{1}{2}$
0	1
1	2
2	4
3	8

This is the graph of the function.

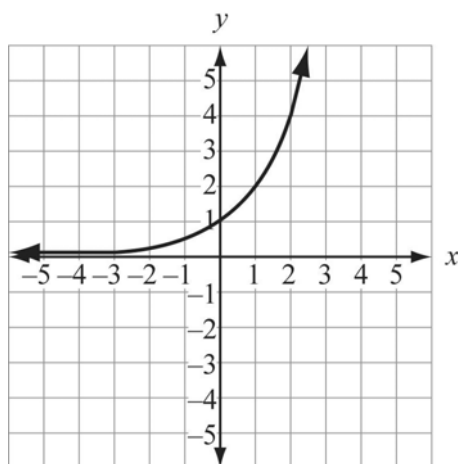

Notice the **end behavior** of the graph. As the value of x increases, the graph moves up to the right, and the value of y increases without bound. As the value of x decreases, the graph moves down to the left and approaches the x -axis or $y = 0$, which is called an **asymptote**.

The **domain** for this function is all real numbers. The **range** is $y > 0$.

Example:

The function $f(x) = 2\left(\frac{1}{2}\right)^x$ is an **exponential decay function**. This is a table of values for the function.

x	$f(x)$
-3	16
-2	8
-1	4
0	2
1	1
2	$\frac{1}{2}$
3	$\frac{1}{4}$

This is the graph of the function.

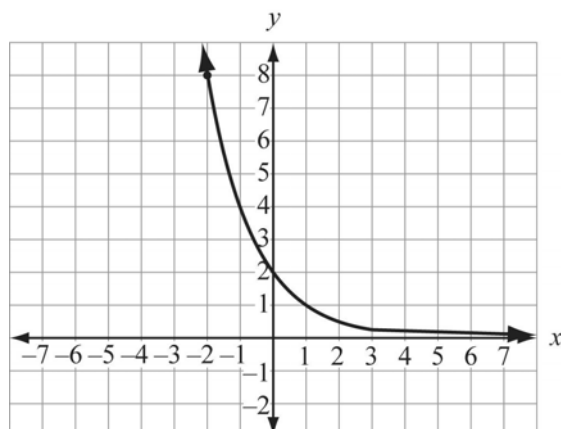

Notice the end behavior of the graph. As the value of x increases, the graph moves down to the right and approaches the x -axis or the asymptote $y = 0$. As the value of x decreases, the graph moves up to the left. As the value of x gets very small, the value of y increases without bound.

The domain for this function is all real numbers. The range is $y > 0$.

5. One, two, three, or all four of the transformations shown below can be applied to an exponential function.
- The graph of $f(x) = b^x$ rewritten in the form $f(x) = ab^{x-h} + k$ is **translated horizontally** to the right h units if $h > 0$ or to the left h units if $h < 0$.
 - The graph of $f(x) = b^x$ rewritten in the form $f(x) = ab^{x-h} + k$ is **translated vertically** up k units if $k > 0$ or down k units if $k < 0$.
 - The graph of $f(x) = b^x$ rewritten in the form $f(x) = ab^{x-h} + k$ is **vertically stretched** if $a > 1$. The graph is **vertically shrunk** if $0 < a < 1$.
 - The graph of $f(x) = b^x$ is **reflected across the x -axis** if b^x is multiplied by -1 . The graph of $f(x) = b^x$ is **reflected across the y -axis** if the exponent x in b^x is multiplied by -1 .

Example:

The graph of $f(x) = 2^x$ rewritten in the form $f(x) = 3(2^{x-1}) + 6$ is translated horizontally to the right 1 unit, translated vertically up 6 units, and vertically stretched by a factor of 3.

Example:

This coordinate grid shows the graphs of $f(x) = 2^x$ and $f(x) = -2^x$.

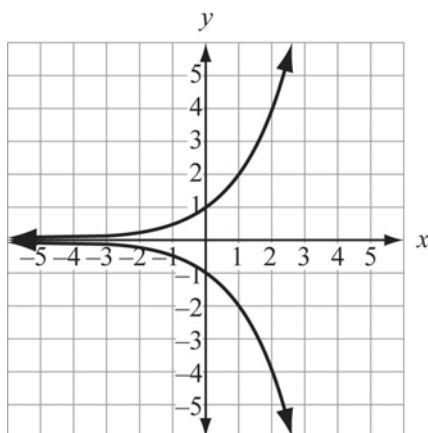

Remember that -2^x is the same thing as $-(2^x)$.

Example:

This coordinate grid shows the graphs of $f(x) = 3^x$ and $f(x) = 3^{-x}$.

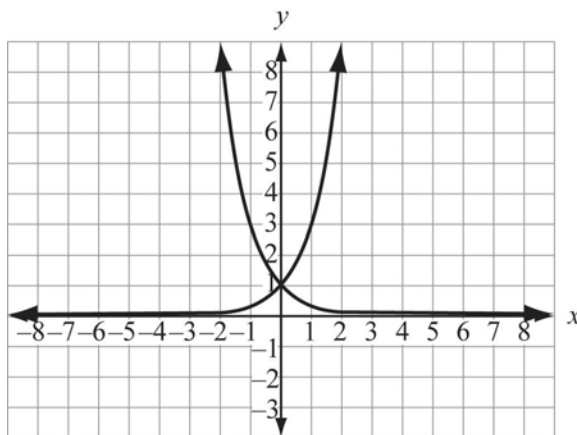

Remember that 3^{-x} can be rewritten as $\left(\frac{1}{3}\right)^x$ using the rule of exponents.

The function $f(x) = 3^x$ is a growth function and $f(x) = 3^{-x}$ is a decay function.

6. The graph of an exponential function written in the form $f(x) = ab^x$ passes through the point $(0, a)$ and approaches the x -axis as an asymptote. To graph an exponential function in the form $f(x) = ab^{x-h} + k$, first sketch the graph of $f(x) = ab^x$ and then translate the graph horizontally by h units and vertically by k units.
7. A **geometric sequence** can be written as an exponential function with a domain that consists of positive integers. In a geometric sequence, the ratio of any term to its preceding term is constant. The **constant ratio** is called the **common ratio** and is the base of the associated exponential function. The n th term of a geometric sequence with the first term a_1 and with a common ratio r is $f(n) = ar^{n-1}$.

Example:

A geometric sequence is given as $(2, 6, 18, 54, \dots)$. This sequence starts with the number 2. To get the next term in the sequence you always multiply by 3. This is the common ratio. The sequence is represented by the function $f(n) = 2(3)^{n-1}$.

The first three terms of the sequence are found using the function, as shown below.

First term:

$$f(n) = 2(3)^{n-1}$$

$$f(1) = 2(3)^{1-1} = 2(3)^0 = 2(1) = 2$$

Second term:

$$f(n) = 2(3)^{n-1}$$

$$f(2) = 2(3)^{2-1} = 2(3)^1 = 2(3) = 6$$

Third term:

$$f(n) = 2(3)^{n-1}$$

$$f(3) = 2(3)^{3-1} = 2(3)^2 = 2(9) = 18$$

8. The **natural base** e is an irrational number. It is defined as $\lim_{n \rightarrow \infty} \left(1 + \frac{1}{n}\right)^n$. As n increases, the value of the expression $\left(1 + \frac{1}{n}\right)^n$ approaches e , and $e \approx 2.718281828459$. The natural base e is used in the formula $A = Pe^{rt}$ to calculate continuously compounded interest.

REVIEW EXAMPLES

- 1) A city's population is 12,800. It is predicted that the population will increase by 3% each year.
- Write a function that can be used to find the city's population after n years.
 - If the city's population, p , continues to grow 3% per year, what will the approximate population be in 15 years?

Solution:

- $p(n) = 12,800 \cdot (1.03)^n$
- $p(n) = 12,800 \cdot (1.03)^n$
 $p(15) = 12,800 \cdot (1.03)^{15}$
 $p = 12,800 \cdot 1.557967417$
 $p \approx 19,942$

- 2) Deb bought a new boat for \$20,000. She estimates that the value of the boat will decrease by 12% each year.
- Write an exponential decay function that represents the value of the boat after t years.
 - Graph the exponential decay function from part a.
 - What is the domain of the function?
 - What is the range of the function?
 - What is the asymptote of the graph?
 - After how many years will the boat have a value of about \$4,900?

Solution:

- $f(x) = 20,000(1 - 0.12)^t$
-

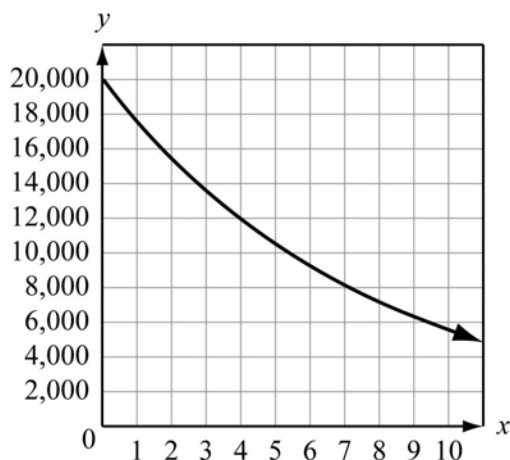

- c. all real numbers greater than or equal to 0
- d. all values of y so that $0 < y \leq 20,000$
- e. The asymptote is the x -axis.
- f. 11 years

EOCT Practice Items

1) The function $f(x)$ has these properties.

- As x increases, $f(x)$ approaches 3.
- As x decreases, $f(x)$ increases.
- The domain of $f(x)$ is all real numbers.

Which of the following could be the function?

- A. $f(x) = -2^{x-3}$
- B. $f(x) = \left(\frac{1}{2}\right)^{x-3}$
- C. $f(x) = -2^x + 3$
- D. $f(x) = \left(\frac{1}{2}\right)^x + 3$

[Key: D]

2) Which graph represents $f(x) = \left(\frac{1}{2}\right)^{x+1} + 3$?

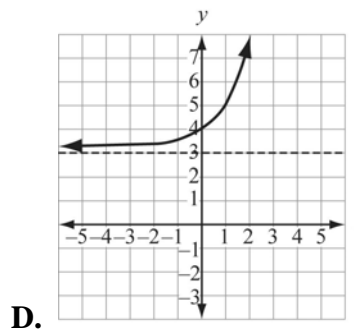
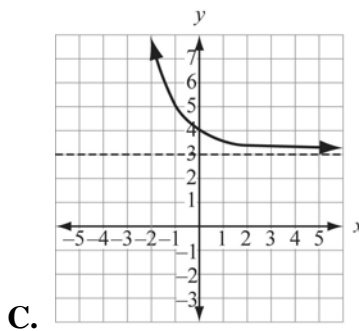
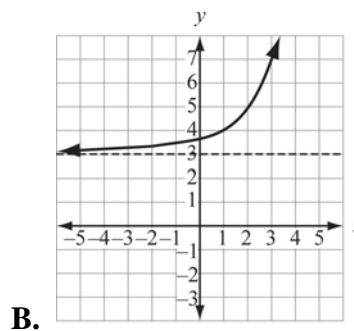
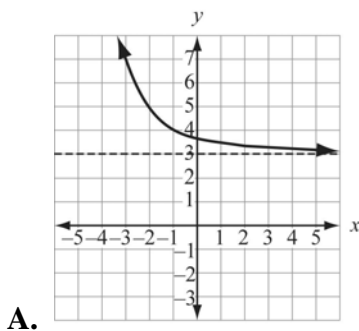

[Key: A]

COMPOSITION AND INVERSE FUNCTIONS



KEY IDEAS

1. The **composition of functions** is a method of combining functions. The composition of functions $f(x)$ and $g(x)$ is written $(f \circ g)(x)$ and is defined by $(f \circ g)(x) = f[g(x)]$.

Example:

Let $f(x) = x^2$ and $g(x) = 2x + 3$. Find $(f \circ g)(x)$.

$$\begin{aligned} (f \circ g)(x) &= f[g(x)] \\ \text{Substitute } 2x + 3 \text{ for } g(x) &= f(2x + 3) \end{aligned}$$

$$\begin{aligned} \text{It was given that} & \quad f(x) = x^2 \\ \text{So it follows that} & \quad f(2x + 3) = (2x + 3)^2 \\ \text{That simplifies to} & \quad = 4x^2 + 12x + 9 \end{aligned}$$

$$\text{So} \quad (f \circ g)(x) = 4x^2 + 12x + 9$$

Example:

Let $f(x) = x^2$ and $g(x) = 2x + 3$. Find $(g \circ f)(x)$.

$$\begin{aligned} (g \circ f)(x) &= g[f(x)] \\ \text{Substitute } x^2 \text{ for } f &= g(x^2) \end{aligned}$$

$$\begin{aligned} \text{It was given that} & \quad g(x) = 2x + 3 \\ \text{So it follows that} & \quad g(x^2) = 2(x^2) + 3 \\ \text{That simplifies to} & \quad = 2x^2 + 3 \end{aligned}$$

$$\text{So} \quad (g \circ f)(x) = 2x^2 + 3$$

Notice that although the two examples are compositions of the same two functions, the order in which they are listed makes a difference in the outcome.

2. An **inverse function** reverses the process of the original function. A function maps the input values onto the output values. An inverse function maps the output values onto the original input values. Switching the x -values and the y -values in an input-output table produces an inverse function. The same thing is true if the x and the y variables are

switched in an equation. The inverse of a function is denoted by f^{-1} and is read “ f inverse.”

3. The input (domain) and output (range) values of all functions have a **one-to-one** relationship. For each input, there is exactly one output. If a function has an inverse that is also a function, then the input and output values of the inverse function must also have a one-to-one relationship. Therefore, a function that has an inverse that is a function is called a **one-to-one function**.

Tables of some values of the function $f(x) = x^3$ and its inverse are shown below. Notice that both tables show a one-to-one relationship. This one-to-one relationship is true for all values of both x and $f(x)$ for both the original function and its inverse. Therefore, the function $f(x) = x^3$ is a one-to-one function.

Example:

Original Function		Inverse Function	
x	$f(x)$	x	$g(x)$
-2	-8	-8	-2
-1	-1	-1	-1
0	0	0	0
1	1	1	1
2	8	8	2

4. A function may or may not have an inverse function. You can use the **horizontal line test** on the graph of a function to determine if it has an inverse function. If there is no horizontal line that intersects the graph at more than one point, then it will have an inverse function. If the inverse maps an x value with more than one y -value, then it is not an inverse function. It can, however, be an inverse relation.

Example:

This is a graph of the function $f(x) = x^2$.

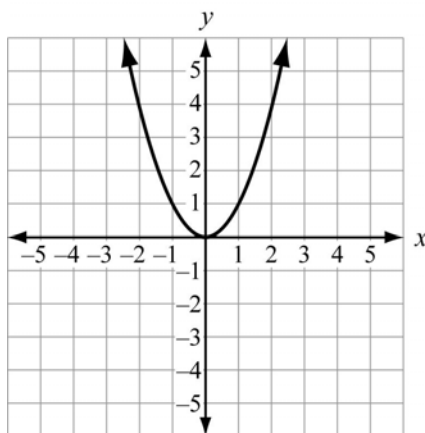

The function $f(x) = x^2$ is not a one-to-one function. There is at least one horizontal line that intersects the graph at more than one point. In other words, at least one y -value is paired with two different x -values, as in the case where a horizontal line passes through $(-1, 1)$ and $(1, 1)$.

The graph of the inverse of the relation $f(x) = x^2$ is clearly not a function since it does not pass the vertical line test of functions, as shown in the graph below. In other words, at least one x -value is paired with two different y -values, as in the case where a vertical line passes through $(4, 2)$ and $(4, -2)$.

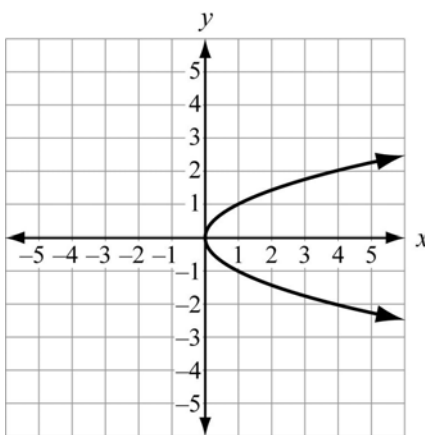

5. A function that is not a one-to-one function when its domain is the set of all real numbers may become a one-to-one function if the domain is restricted appropriately. For example, the function $f(x) = x^2$ as shown in Key Idea #4 is not a one-to-one function. However, if the domain is restricted to only positive real numbers, it is a one-to-one function, as shown on the next page.

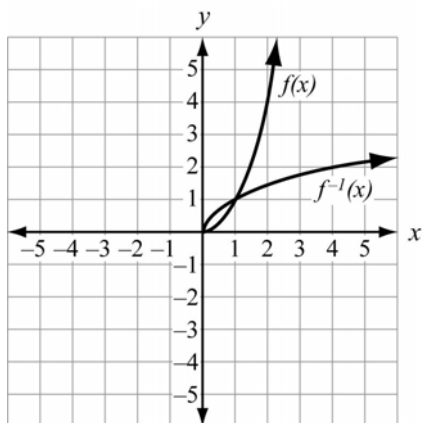

Important Tip

Notice that the graph of the inverse of the function is the same as the reflection of the function across the line $y = x$.

6. All linear functions *except* horizontal lines are one-to-one functions.
7. Another way to verify that two functions are inverses of each other is by using composition. The composition of the two functions must give the *identity function* which is $f(x) = x$.

Example:

Show that the two functions $f(x) = 2x + 3$ and $g(x) = \frac{x-3}{2}$ are inverses of each other.

Find $f[g(x)]$.

or

Find $g[f(x)]$.

$$\begin{aligned} f[g(x)] &= f\left(\frac{x-3}{2}\right) \\ &= 2\left(\frac{x-3}{2}\right) + 3 \\ &= x - 3 + 3 \\ &= x \end{aligned}$$

$$\begin{aligned} g[f(x)] &= g(2x + 3) \\ &= \frac{2x + 3 - 3}{2} \\ &= \frac{2x}{2} \\ &= x \end{aligned}$$

Since $f[g(x)] = g[f(x)] = x$, then the composition of the functions gives the identity function and the functions are inverses of each other. You only need to find one composition to verify that the functions are inverses of each other. However, it can be a good idea to find both compositions as a way of verifying that your work is correct.

8. The inverse of a function in the form $f(x) = \frac{a}{x}$ or $y = \frac{a}{x}$ is the same function. The graph of $f(x) = \frac{2}{x}$ is shown below.

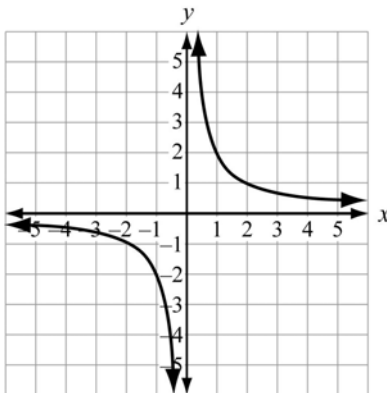

If this graph is reflected across the line $y = x$, the result is the same graph.

This is the table for the function $f(x) = \frac{2}{x}$.

x	$f(x)$
-4	$-\frac{1}{2}$
-3	$-\frac{2}{3}$
-2	-1
-1	-2
0	undefined
1	2
2	1
3	$\frac{2}{3}$
4	$\frac{1}{2}$

If you swap the x values for the y values in the table and graph them, it is the same graph. Notice that the domain for the function is the set of all real numbers except 0. The function is undefined at $x = 0$.

REVIEW EXAMPLES

1) A table of values for the function $f(x)$ is shown below.

x	$f(x)$
-2	-7
-1	0
0	1
1	2
2	9
3	28

- What is the table of values for the inverse of the function?
- Is $f(x)$ a one-to-one function? Explain your reasoning.

Solution:

a.

x	$f(x)$
-7	-2
0	-1
1	0
2	1
9	2
28	3

- It is a one-to-one function because the table of the inverse of the function also represents a function. For each input number there is exactly one output number.

2) Verify that $f(x) = \frac{1}{4}x^2$, $x \geq 0$, and $g(x) = \sqrt{4x}$ are inverse functions.

Solution:

Find $f(g(x))$.

$$\begin{aligned}
 f(g(x)) &= f(\sqrt{4x}) \\
 &= \frac{1}{4}(\sqrt{4x})^2 \\
 &= \frac{1}{4}(4x) \\
 &= x
 \end{aligned}$$

Since the composition equals x , then the functions are inverses.

EOCT Practice Items

1) Use this function to answer the question.

$$f(x) = \frac{2}{x} + 3$$

What value is NOT included in the domain of the inverse of this function?

- A. 0
- B. 1
- C. 2
- D. 3

[Key: D]

2) Use these functions to answer the question.

$$f(x) = 4x - 2$$

$$g(x) = \frac{x + 2}{4}$$

$$f(g(x)) = x$$

Which statement about the functions $f(x)$ and $g(x)$ is true?

- A. They are inverse functions because $f(g(x))$ is not equal to 0.
- B. They are inverse functions because $f(g(x))$ is equal to x .
- C. They are not inverse functions because $f(g(x))$ is not equal to 0.
- D. They are not inverse functions because $f(g(x))$ is equal to x .

[Key: B]

Unit 6

Statistics: Algebraic Models for Quantitative Data

This unit investigates linear and quadratic regression. Students look at bivariate data to determine which type of curve best fits the data, including the extent to which a given line or curve is or is not a good fit for the data. Students use methods such as the median-median line and estimation to determine the equation of an appropriate line or curve to fit a given set of data, and use the equation to make predictions and analyze a real-world relationship.

Note: For the purposes of the Georgia End-of-Course Test, it is not possible to presume that all students will have access to technology that will apply the processes of linear and quadratic regression for curve fitting. As a result, determining the line or curve of best fit will not be directly assessed on the Georgia End-of-Course Test. Instead, the test will focus on assessing whether a given line or function is an appropriate model for a set of data.

KEY STANDARD

MM2D2. Students will determine an algebraic model to quantify the association between two quantitative variables.

- a. Gather and plot data that can be modeled with linear and quadratic functions.
- b. Examine the issues of curve fitting by finding good linear fits to data using simple methods such as the median-median line and “eyeballing.”
- c. Understand and apply the processes of linear and quadratic regression for curve fitting using appropriate technology.
- d. Investigate issues that arise when using data to explore the relationship between two variables, including confusion between correlation and causation.

DETERMINING AN APPROPRIATE ALGEBRAIC MODEL



KEY IDEAS

1. **Bivariate data** are data that involve two variables that may be related to each other. The data can be presented as ordered pairs and in any way that ordered pairs can be presented: as a set of ordered pairs, as a table of values, or as a graph on the coordinate plane.
2. Bivariate data may have an underlying relationship that can be modeled by a mathematical function. For the purposes of this unit, we will consider models that are either **linear** or **quadratic** functions.

Example:

Evan is researching if there is a relationship between study time and mean test scores. He recorded the mean study time per test and the mean test score for students in four different courses. This is the data for Course 1.

Course 1

Mean Study Time (hours)	Mean Test Score
0.5	65
1.0	71
1.5	75
2.0	82
2.5	84
3.0	90
3.5	95

Notice that, for these data, as the mean study time increases, the mean test score increases. It is important to consider the *rate of increase* when deciding which algebraic model to use. In this case, the mean test score increases by approximately 5 points for each 0.5-hour increase in mean study time. When the rate of increase is close to constant as it is here, the best model is most likely a linear function.

This table shows Evan's data for Course 2.

Course 2

Mean Study Time (hours)	Mean Test Score
0.5	65
1.0	66
1.5	68
2.0	73
2.5	79
3.0	87
3.5	98

In these data as well, the mean test score increases as the mean study time increases. However, the rate of increase is not constant. The differences between each successive mean test score are 1, 2, 5, 6, 8, and 11. The *second differences* are 1, 3, 1, 2, and 3. Since the second differences are fairly close to constant, it is likely that a quadratic function would be a good model for the data for Course 2.

This table shows Evan's data for Course 3.

Course 3

Mean Study Time (hours)	Mean Test Score
0.5	65
1.0	74
1.5	80
2.0	84
2.5	86
3.0	85
3.5	81

In these data, the mean test score increases as the mean study time increases, but after a maximum point is reached the mean test score appears to decrease. The rate of increase decreases as it approaches the maximum, then, after the maximum is met, the rate of decrease increases. This is the characteristic behavior of a quadratic function that has a maximum, so it is likely that a quadratic function would be a good model for the data for Course 3 as well. However, since the function appears to have a maximum, the value of the coefficient of x^2 would be negative rather than positive as it would be for Course 2.

This table shows Evan's data for Course 4.

Course 4

Mean Study Time (hours)	Mean Test Score
0.5	74
1.0	91
1.5	82
2.0	92
2.5	70
3.0	76
3.5	90

In these data, as the mean study time increases, there is no consistent pattern in the mean test score. As a result, there does not appear to be any clear relationship between mean study time and mean test score for this particular course.

Often, patterns in bivariate data are more easily seen when the data is plotted on a coordinate grid.

Example:

This graph shows Evan's data for Course 1.

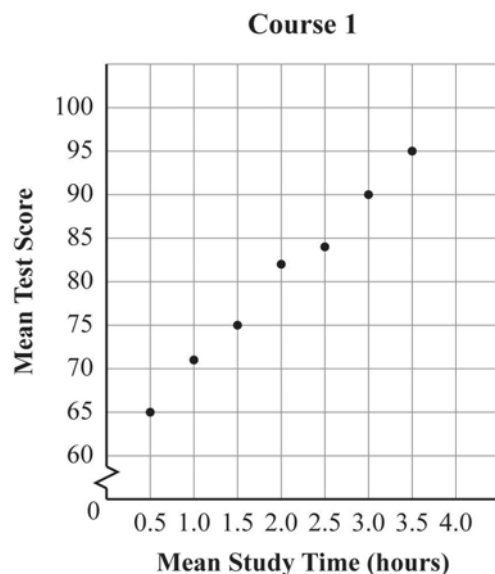

In this graph, the data points are all very close to being on the same line. This is further confirmation that a linear model is appropriate for this course.

This graph shows Evan's data for Course 2.

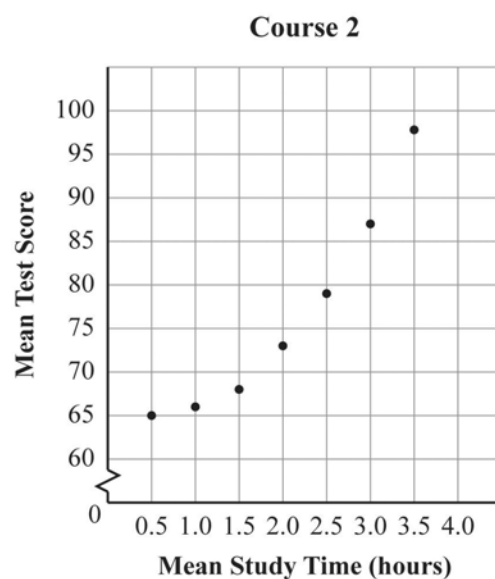

In this graph, the data points appear to lie on a curve, rather than on a line, with a rate of increase that increases as the value of x increases. It appears that a quadratic or exponential model may be more appropriate than a linear model for these data.

This graph shows Evan's data for Course 3.

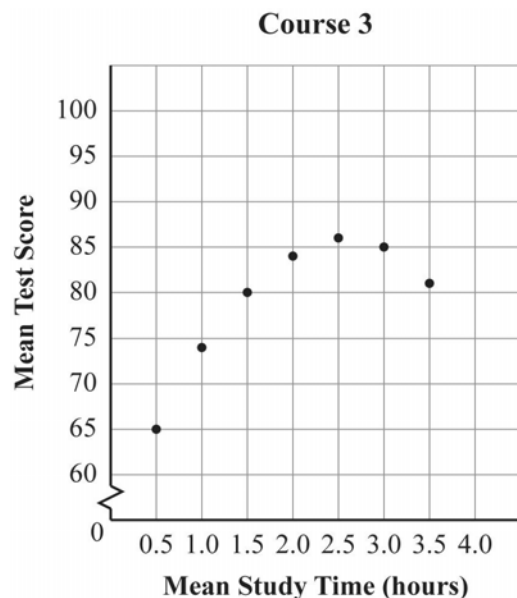

In this graph, the data points appear to lie on a curve, rather than on a line, as well. However, in this case, the curve appears to have a maximum somewhere around $x = 2.5$ hours. As a result, a quadratic model appears to be a good fit for this set of data.

LINEAR MODELS



KEY IDEAS

1. The extent to which a linear model does or does not fit a set of data is known as **correlation**. The amount of correlation is found by determining the distance of the data points from the **line of best fit**, which is the line that minimizes that distance. Correlation is usually expressed as a value between 1 and -1 , with 1 representing perfect correlation, 0 representing no correlation, and -1 representing perfectly negative correlation. In the context of the data relating study time and quiz grades, the correlation would be negative if the mean test score decreased as study time increased.
2. The **median-median line** is a way to estimate a line of best fit that involves relatively simple calculations. Since it involves using medians, it is also somewhat resistant to the effect of outliers in the data. To calculate a median-median line, order the data from the least to the greatest value of the x -coordinate. Order data points that have the same value of x from the least to the greatest value of the y -coordinate. Next, use this ordering to divide the data into three equal groups. Find the median x -coordinate value for each of the

three groups (low values, middle values, high values). Then find the median of the y -values associated with each of these data points. Note that the median values of x and y may or may not be associated with the same data point. Find the equation of the line containing the two outside points (the points from the low- x and the high- x value sets).

Then adjust the position of the line by moving it $\frac{1}{3}$ of the way toward the middle point.

Note: Each item on the *Mathematics II EOCT* that asks students to find the median-median line requires this method of calculation. Graphing calculators are currently not permitted for use during the *Mathematics II EOCT*. Students should become familiar with this method as preparation for the assessment.

Example:

This graph shows Evan's data for Course 1 with the line of best fit added. The equation of the line is $y = 10x + 60$.

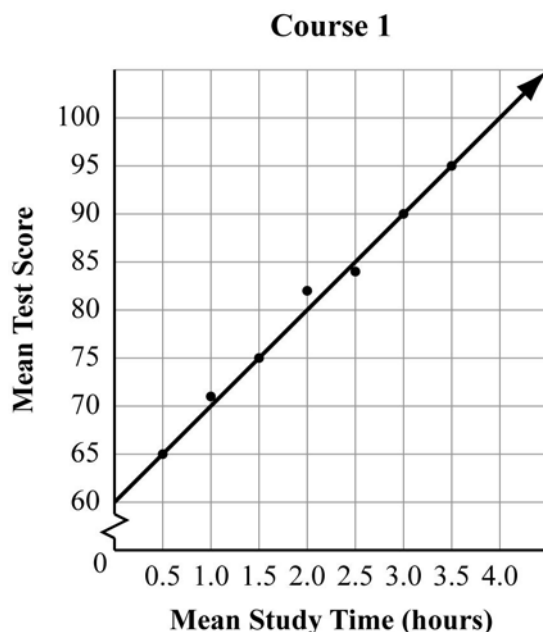

Notice that four of the seven data points are on the line. This represents a very strong correlation. Since the slope of the line is positive, the correlation is positive.

This graph shows Evan's data for Course 4 with the line of best fit added. The equation of the line is $y = 0.4x + 81.3$.

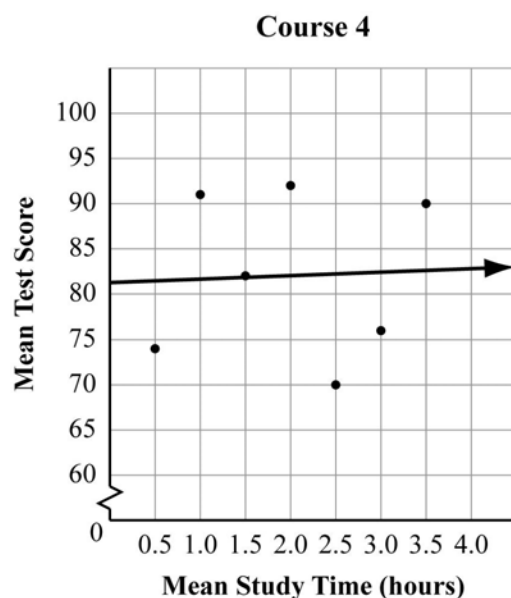

Although a line of best fit can be calculated for this set of data, notice that most of the data points are not very close to the line. In this case, although there is some correlation between study time and test scores, the amount of correlation is very small.

REVIEW EXAMPLE

- 1) Tina collected the height in inches and the shoe size of a random sample of nine boys in her class. Her data is shown in this list.

$$\{(62, 6.5) (64, 7) (64, 8) (65, 8) (67, 8.5) (68, 10) (69, 9.5) (69, 11.5) (73, 11)\}$$

In each ordered pair, the x -coordinate is the height in inches and the y -coordinate is the shoe size.

Find the equation of the median-median line for Tina's data.

Solution:

Tina's data is already in order from the least to the greatest x -value. The lowest set of x -values is $\{62, 64, 64\}$. The middle set is $\{65, 67, 68\}$. The highest set is $\{69, 69, 73\}$. The median values of x for these sets are 64, 67, and 69. For the lowest set, there are two data points that contain the value 64. The median point is $(64, 7)$ because it is the middle point in the order. Similarly, the median point in the highest set is $(69, 11)$. Note that the y -value is *not* the median value of y for that set of three points; it is the y -value of the middle point.

Next, find the value of the line that contains the points (64, 7) and (69, 11).

The slope is $\frac{(11-7)}{(69-64)} = \frac{4}{5} = 0.8$. The y -intercept, b , is

$$7 = 0.8(64) + b$$

$$7 = 51.2 + b$$

$$-44.2 = b$$

The equation of the line containing the median points of the lowest and highest sets is $y = 0.8x - 44.2$. To adjust toward the median point of the middle set, plug the x -value of that point into the equation we just found.

$$y = 0.8(67) - 44.2$$

$$y = 53.6 - 44.2$$

$$y = 9.4$$

So the expected value of y from that equation is 9.4. The y -value of the median point is 8.5. This is 0.9 less than the expected value of y . One-third of that distance is 0.3, so subtract 0.3 from the y -intercept in the equation above to find the equation of the median-median line.

$$y = 0.8x - (44.2 - 0.3)$$

$$y = 0.8x - 43.9$$

QUADRATIC MODELS



KEY IDEA

Data such as that which Evan collected for Course 2 and Course 3 can be modeled by a quadratic function. As with data that can be modeled by a linear function, the idea is to choose a function that will minimize the distances from each data point to the graph of the function.



Important Tip

Even when a quadratic function appears to be a good model for a particular set of data, it is important to consider the context when making predictions based on that model. For example, in the context of study time vs. test scores, a quadratic function may not be an appropriate model for values outside the ones in Evan's data. According to the model for the Course 2 data, as mean study time increases beyond 3.5 hours, mean test scores should continue to increase at an increasing rate. However, in most cases there is a maximum possible test score.

Example:

This graph shows Evan's data for Course 2 with the quadratic regression curve added. The equation of the curve is $y = 3.9x^2 - 4.8x + 66.6$.

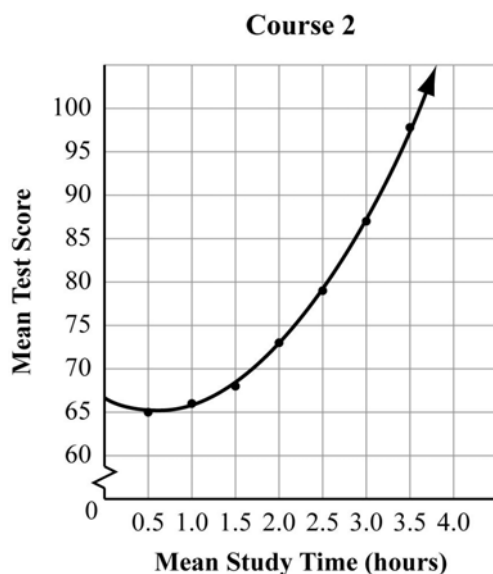

Notice that all seven data points are very close to being on the curve, so this function is a very good model for these data. However, it may not be appropriate to use this model to predict the mean test score associated with a mean study time of six hours. Substituting a

value of $x = 6$ into this model gives this predicted test score:

$$y = 3.9(6)^2 - 4.8(6) + 66.6 = 140.4 - 28.8 + 66.6 = 178.2$$

If the maximum possible test score is 100, this model is clearly inappropriate for x -values greater than 3.5.

This graph shows Evan's data for Course 3 with the quadratic regression curve added. The equation of the curve is $y = -4.95x^2 + 25.2x + 53.6$. Notice that the negative coefficient of the x^2 term indicates that this is a quadratic function with a graph that opens down, which means that it has a maximum value.

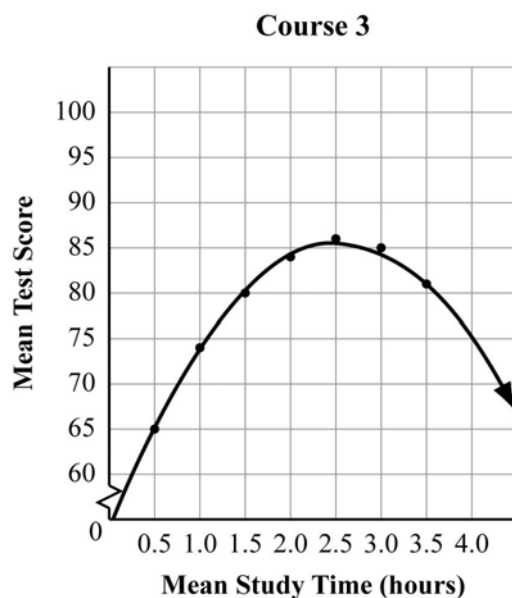

Notice again that all seven data points are very close to being on the curve, so this function is a very good model for these data. As in the previous model, it may not be appropriate to use this model to predict the mean test score associated with a mean study time of six hours. Substituting a value of $x = 6$ into this model gives this predicted test score: $y = -4.95(6)^2 + 25.2(6) + 53.6 = -178.2 + 151.2 + 53.6 = 26.6$

In this case, while a mean test score of about 27 is possible, it seems unlikely that students who studied for that long would have such low test scores.



Important Tip

When deciding whether or not a quadratic function is an appropriate model for a data set, you can make a table of values to show the y -values that the function predicts for the values of x in the data set and compare those y -values to the actual values from the data. This is also a good way to decide whether or not the quadratic model is appropriate for values outside the domain of the given data.

EOCT Practice Items

1) For which graph of a set of data is a linear function the best model?

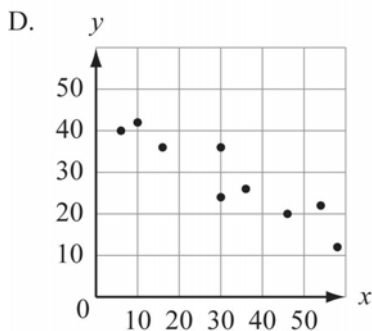
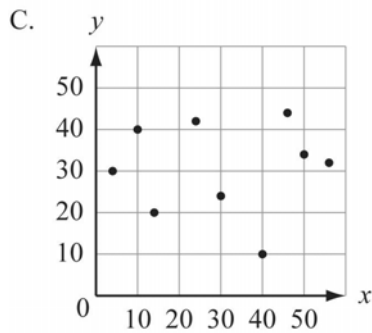
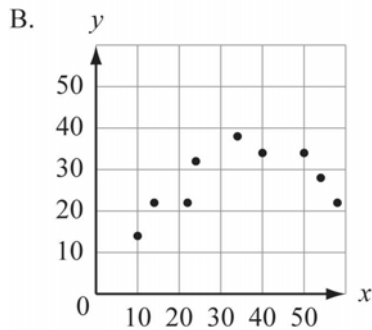
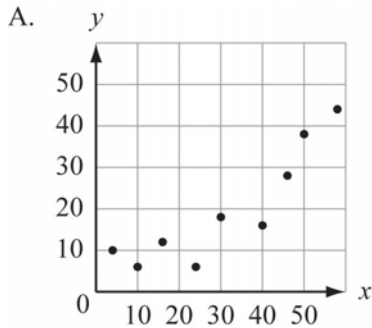

[Key: D]

- 2) This graph plots the number of wins in the 2006 and 2007 seasons for a sample of professional football teams.

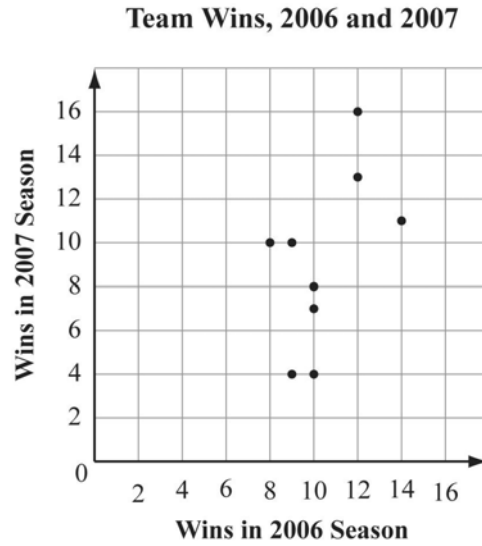

What is the equation of the median-median line for these data?

- A. $y = x + 1$
- B. $y = x - \frac{1}{3}$
- C. $y = 4x - 32\frac{1}{3}$
- D. $y = 4x - 32$

[Key: B]

- 3) This graph plots the number of wins in the 2006 and 2007 seasons for a sample of professional football teams.

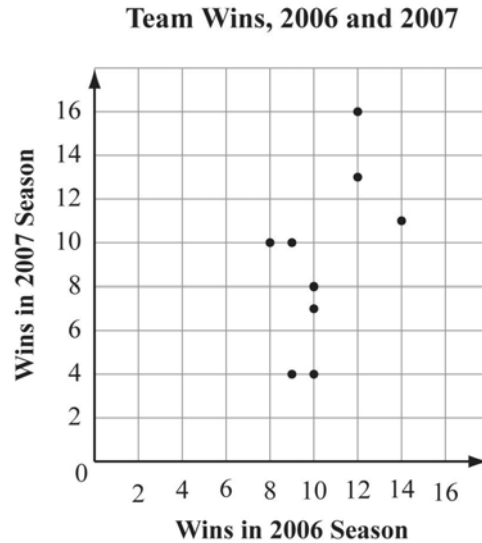

The linear regression model for these data is $y = 1.10x - 2.29$. Based on this model, what is the predicted number of 2007 wins for a team that won 5 games in 2006?

- A. 3
- B. 4
- C. 5
- D. 6

[Key: A]

- 4) This graph shows the expected income from sales vs. price per issue for a new magazine.

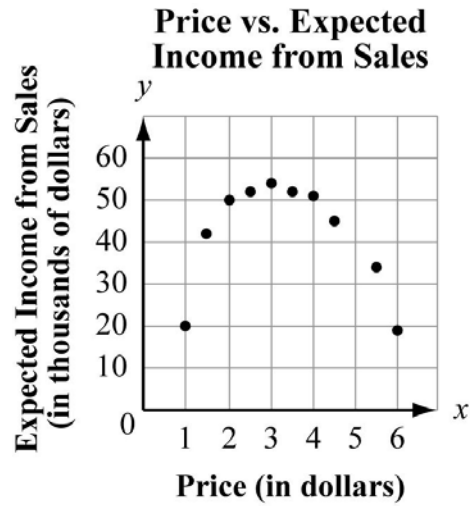

Which equation models these data?

- A. $y = -5.1x^2 + 34.4x - 3.0$
B. $y = 5.1x^2 - 34.4x + 3.0$
C. $y = -34.4x^2 + 5.1x - 3.0$
D. $y = 34.4x^2 - 5.1x + 3.0$

[Key: A]

5) This graph shows the price of a new audio-visual component over time.

**Price of New Audio-Visual
Component Over Time**

Year	Median Price (in dollars)
0	500
2	425
4	360
6	280
8	200

Which is the best explanation for why a linear model may not be appropriate for these data?

- A. The median price decreases over time.
- B. The value of the median price cannot be negative.
- C. The value of the median price cannot continue to decrease.
- D. A quadratic model would be a better fit because the rate of decrease is decreasing.

[Key: B]

Appendix A

EOCT Sample Overall Study Plan Sheet

Here is a sample of what an OVERALL study plan might look like. You can use the Blank Overall Study Plan Sheet in Appendix B or create your own.

Materials/Resources I May Need When I Study:

(You can look back at page 2 for ideas.)

1. *This study guide*
2. *Pens*
3. *Highlighter*
4. *Notebook*
5. *Dictionary*
6. *Calculator*
7. *Mathematics textbook*

Possible Study Locations:

- First choice: *The library*
- Second choice: *My room*
- Third choice: *My mom's office*

Overall Study Goals:

1. *Read and work through the entire study guide.*
2. *Answer the sample questions and study the answers.*
3. *Do additional reading in a mathematics textbook.*

Number of Weeks I Will Study: *6 weeks*

Number of Days a Week I Will Study: *5 days a week*

Best Study Times for Me:

- Weekdays: *7:00 p.m. – 9:00 p.m.*
- Saturday: *9:00 a.m. – 11:00 a.m.*
- Sunday: *2:00 p.m. – 4:00 p.m.*

Appendix B

Blank Overall Study Plan Sheet

Materials/Resources I May Need When I Study:
(You can look back at page 2 for ideas.)

1. _____
2. _____
3. _____
4. _____
5. _____
6. _____

Possible Study Locations:

- First choice: _____
- Second choice _____
- Third choice _____

Overall Study Goals:

1. _____
2. _____
3. _____
4. _____
5. _____

Number of Weeks I Will Study: _____

Number of Days a Week I Will Study: _____

Best Study Times for Me:

- Weekdays: _____
- Saturday: _____
- Sunday: _____

Appendix C

EOCT Sample Daily Study Plan Sheet

Here is a sample of what a DAILY study plan might look like. You can use the Blank Daily Study Plan Sheet in Appendix D or create your own.

Materials I May Need Today:

1. *Study guide*
2. *Pen/pencil*
3. *Notebook*

Today's Study Location: *The desk in my room*

Study Time Today: *From 7:00 p.m. to 8:00 p.m. with a short break at 7:30 p.m.*

(Be sure to consider how long you can actively study in one sitting. Can you sit for 20 minutes? 30 minutes? An hour? If you say you will study for three hours, but get restless after 40 minutes, anything beyond 40 minutes may not be productive—you will most likely fidget and daydream your time away. “Doing time” at your desk doesn’t count as real studying.)

If I Start to Get Tired or Lose Focus Today, I Will: *Do some sit-ups*

Today's Study Goals and Accomplishments: (Be specific. Include things like number of pages, units, or standards. The more specific you are, the better able you will be to tell if you reached your goals. Keep it REALISTIC. You will retain more if you study small “chunks” or blocks of material at a time.)

<i>Study Task</i>	<i>Completed</i>	<i>Needs More Work</i>	<i>Needs More Information</i>
<i>1. Review what I learned last time</i>	X		
<i>2. Study the first main topic in Unit 1</i>	X		
<i>3. Study the second main topic in Unit 1</i>		X	

What I Learned Today:

1. *Reviewed horizontal and vertical shifts*
2. *Locating the vertex of a quadratic function*
3. *Reviewed the definitions of an arithmetic series*

Today's Reward for Meeting My Study Goals: *Eating some popcorn*

Appendix D Blank Daily Study Plan Sheet

Materials I May Need Today:

1. _____
2. _____
3. _____
4. _____
5. _____

Today’s Study Location: _____

Study Time Today: _____

(Be sure to consider how long you can actively study in one sitting. Can you sit for 20 minutes? 30 minutes? An hour? If you say you will study for three hours, but get restless after 40 minutes, anything beyond 40 minutes may not be productive—you will most likely fidget and daydream your time away. “Doing time” at your desk doesn’t count for real studying.)

If I Start To Get Tired or Lose Focus Today, I Will: _____

Today’s Study Goals and Accomplishments: (Be specific. Include things like number of pages, sections, or standards. The more specific you are, the better able you will be to tell if you reached your goals. Keep it REALISTIC. You will retain more if you study small “chunks” or blocks of material at a time.)

<i>Study Task</i>	<i>Completed</i>	<i>Needs More Work</i>	<i>Needs More Information</i>
1.			
2.			
3.			
4.			
5.			

What I Learned Today:

1. _____
2. _____
3. _____

Today’s Reward for Meeting My Study Goals: _____